

SCAG[®]

POWER EQUIPMENT

OPERATOR'S MANUAL



Tiger Cat

Models: STC48V-22FS
STC48V-22FS-LE
STC48V-25CV
STC48V-26BS
STC52V-24FX
STC52V-27CV
STC61V-27CV

Congratulations on owning a Scag mower! This manual contains the operating instructions and safety information for your Scag mower. Reading this manual can provide you with assistance in maintenance and adjustment procedures to keep your mower performing to maximum efficiency. The specific models that this book covers are listed on the inside cover. Before operating your machine, please read all the information enclosed.



WARNING

FAILURE TO FOLLOW SAFE OPERATING PRACTICES MAY RESULT IN SERIOUS INJURY OR DEATH.

- Read this manual completely as well as other manuals that came with your mower.
- DO NOT operate on steep slopes. To check a slope, attempt to back up it (with the cutter deck down). If the machine can back up the slope without the wheels slipping, reduce speed and use extreme caution.
- Under no circumstances should the machine be operated on slopes greater than 15 degrees. ALWAYS FOLLOW OSHA APPROVED OPERATION.
- DO NOT mow on wet grass. Wet grass reduces traction and steering control.
- Keep all shields in place, especially the grass discharge chute.
- Before performing any maintenance or service, stop the machine and remove the spark plug wire and ignition key.
- If a mechanism becomes clogged, stop the engine before cleaning.
- Keep hands, feet and clothing away from power-driven parts.
- Keep others off the mower (only one person at a time)

REMEMBER - YOUR MOWER IS ONLY AS SAFE AS THE OPERATOR!

HAZARD CONTROL AND ACCIDENT PREVENTION ARE DEPENDENT UPON THE AWARENESS, CONCERN, PRUDENCE, AND PROPER TRAINING OF THE PERSONNEL INVOLVED IN THE OPERATION, TRANSPORT, MAINTENANCE, AND STORAGE OF THE EQUIPMENT.

This manual covers the operating instructions and illustrated parts list for:

STC48V-22FS	with a serial number of	F7400001 to F7499999
STC48V-22FS-LE	with a serial number of	F7600001 to F7699999
STC48V-25CV	with a serial number of	F3900001 to F3999999
STC48V-26BS	with a serial number of	F4000001 to F4099999
STC52V-24FX	with a serial number of	F4100001 to F4199999
STC52V-27CV	with a serial number of	F4200001 to F4299999
STC61V-27CV	with a serial number of	F4300001 to F4399999

Always use the entire serial number listed on the serial number tag when referring to this product.

Table of Contents

SECTION 1 - GENERAL INFORMATION.....	1
1.1 INTRODUCTION.....	1
1.2 DIRECTION REFERENCE	1
1.3 SERVICING THE ENGINE AND DRIVE TRAIN COMPONENTS.....	1
1.4 SYMBOLS	2
SECTION 2 - SAFETY INFORMATION	3
2.1 INTRODUCTION.....	3
2.2 SIGNAL WORDS	3
2.3 BEFORE OPERATION CONSIDERATIONS.....	3
2.4 OPERATION CONSIDERATIONS.....	4
2.5 ROLL-OVER PROTECTION SYSTEM	6
2.6 MAINTENANCE CONSIDERATIONS & STORAGE	8
2.7 USING A SPARK ARRESTOR.....	8
2.8 SPARK IGNITION SYSTEM	8
2.9 SAFETY AND INSTRUCTIONAL DECALS.....	9
SECTION 3 - SPECIFICATIONS	10
3.1 ENGINE	10
3.2 ELECTRICAL	10
3.3 TRACTOR	10
3.4 CUTTER DECK	11
3.5 HYDRAULIC SYSTEM	11
3.6 WEIGHTS AND DIMENSIONS.....	11
3.7 PRODUCTIVITY	11
SECTION 4 - OPERATING INSTRUCTIONS	12
4.1 CONTROLS AND INSTRUMENT IDENTIFICATION	12
4.2 SAFETY INTERLOCK SYSTEM	13
4.3 INITIAL RUN-IN PROCEDURES.....	13
4.4 STARTING THE ENGINE	14
4.5 GROUND TRAVEL AND STEERING	14
4.6 ENGAGING THE DECK DRIVE (CUTTER BLADES).....	15
4.7 HILLSIDE OPERATION.....	16
4.8 PARKING THE MOWER	16
4.9 AFTER OPERATION	16
4.10 REMOVING CLOGGED MATERIAL	16
4.11 MOVING MOWER WITH ENGINE STOPPED	17
4.12 RECOMMENDATIONS FOR MOWING	17
4.13 ADJUSTING CUTTING HEIGHT.....	17
4.14 TOWING (OPTIONAL HITCH ACCESSORY).....	18
SECTION 5 - TROUBLESHOOTING CUTTING CONDITIONS	19

SECTION 6 - ADJUSTMENTS	22
6.1 PARKING BRAKE ADJUSTMENT	22
6.2 TRAVEL ADJUSTMENTS	22
6.3 THROTTLE CONTROL AND CHOKE ADJUSTMENTS	24
6.4 BELT ADJUSTMENT	24
6.5 BELT ALIGNMENT.....	24
6.6 CUTTER DECK ADJUSTMENTS	24
6.7 CUSTOM-CUT BAFFLE ADJUSTMENT	26
6.8 ELECTRIC CLUTCH ADJUSTMENT.....	27
SECTION 7 - MAINTENANCE.....	28
7.1 MAINTENANCE CHART - RECOMMENDED SERVICE INTERVALS	28
7.2 LUBRICATION.....	29
7.3 HYDRAULIC SYSTEM	31
7.4 ENGINE OIL	32
7.5 ENGINE FUEL SYSTEM	32
7.6 ENGINE AIR CLEANER.....	33
7.7 BATTERY.....	34
7.8 DRIVE BELTS.....	35
7.9 CUTTER BLADES.....	35
7.10 TIRES.....	36
7.11 BODY, DECK, AND UPHOLSTERY	36
SECTION 8 - ILLUSTRATED PARTS LIST	37
8.1 SCAG APPROVED ATTACHMENTS AND ACCESSORIES.....	37
48V & 52V CUTTER DECKS	38
61V CUTTER DECK.....	40
CUTTER DECK CONTROLS	42
SHEET METAL COMPONENTS	44
STC FOLDABLE ROLL-OVER PROTECTION SYSTEM	46
STC SEATS	48
DRIVE SYSTEM COMPONENTS	50
ENGINE & ATTACHING PARTS.....	52
STEERING COMPONENTS.....	54
BRAKE COMPONENTS	56
HYDRAULIC SYSTEM	58
STC FUEL SYSTEM - EPA PHASE 2	60
STC FUEL SYSTEM - EPA PHASE 3	62
STC FUEL SYSTEM - C.A.R.B. TIER 3	64
ELECTRICAL SYSTEM	66
BDP-10A HYDRAULIC PUMP ASSEMBLY.....	68
REPLACEMENT DECALS AND INFORMATION PLATES	70
ELECTRICAL SCHEMATIC - BRIGGS & STRATTON / KOHLER	72
ELECTRICAL SCHEMATIC - KAWASAKI.....	73
LIMITED WARRANTY - COMMERCIAL EQUIPMENT	Following Section 8

GENERAL INFORMATION

1.1 INTRODUCTION

Your mower was built to the highest standards in the industry. However, the prolonged life and maximum efficiency of your mower depends on you following the operating, maintenance and adjustment instructions in this manual.

If additional information or service is needed, contact your Scag Power Equipment Dealer.

We encourage you to contact your dealer for repairs. All Scag dealers are informed of the latest methods to service this equipment and provide prompt and efficient service in the field or at their service shop. They carry a full line of Scag service parts.

THE REPLACEMENT OF ANY PART ON THIS PRODUCT BY OTHER THAN THE MANUFACTURER'S AUTHORIZED REPLACEMENT PART MAY ADVERSELY AFFECT THE PERFORMANCE, DURABILITY OR SAFETY OF THIS PRODUCT.

USE OF OTHER THAN ORIGINAL SCAG REPLACEMENT PARTS WILL VOID THE WARRANTY.

When ordering parts, always give the model and serial number of your mower. The serial number plate is located where shown in Figure 1-1.

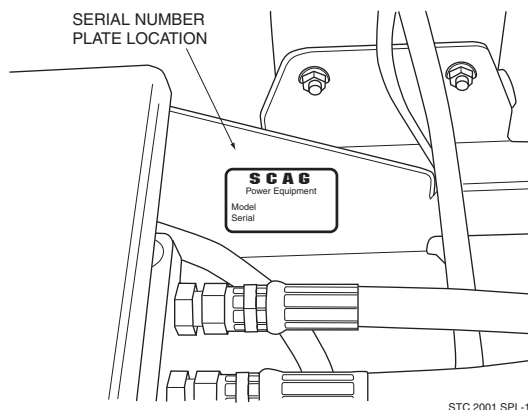

Figure 1-1. Mower Serial Number Plate Location

USE ONLY SCAG APPROVED ATTACHMENTS AND ACCESSORIES.

Attachments and accessories manufactured by companies other than Scag Power Equipment are not approved for use on this machine. See Section 8, Paragraph 8-1.



WARNING

For pictorial clarity, some illustrations and figures in this manual may show shields, guards or plates open or removed. Under no circumstances should your mower be operated without these devices in place.

All information is based upon product information available at the time of approval for printing. Scag Power Equipment reserves the right to make changes at any time without notice and without incurring any obligation.

















1.2 DIRECTION REFERENCE

The “Right” and “Left”, “Front” and “Rear” of the machine are referenced from the operator’s right and left when seated in the normal operating position and facing the forward travel direction.

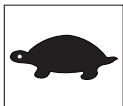
1.3 SERVICING THE ENGINE AND DRIVE TRAIN COMPONENTS

The details of servicing and repair of the engine, hydraulic pumps and gearboxes are not covered in this manual; only routine maintenance and general service instructions are provided. For service of these components during the limited warranty period, it is important to contact your Scag dealer or find a local authorized servicing agent of the component manufacturer. Any unauthorized work done on these components during the warranty period may void your warranty.

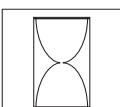
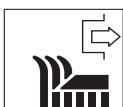
1.4 SYMBOLS

SYMBOL	DESCRIPTION	SYMBOL	DESCRIPTION
	Choke		Transmission
	Parking Brake	 48071B	Spinning Blade
	On/Start		Spring Tension on Idler
	Off/Stop		Oil
	Falling Hazard		Thrown Object Hazard
	Fast		Slow
	Continuously Variable - Linear		Cutting Element - Basic Symbol
 481039S	Pinch Point		Cutting Element - Engage
	Hour meter/Elapsed Operating Hours		Cutting Element - Disengage
	Thrown Object Hazard Keep Bystanders Away		Read Operator's Manual

SAFETY INFORMATION

2.1 INTRODUCTION

Your mower is only as safe as the operator. Carelessness or operator error may result in serious bodily injury or death. Hazard control and accident prevention are dependent upon the awareness, concern, prudence, and proper training of the personnel involved in the operation, transport, maintenance and storage of the equipment. Make sure every operator is properly trained and thoroughly familiar with all of the controls before operating the mower. The owner/user can prevent and is responsible for accidents or injuries occurring to themselves, other people or property.

READ THIS OPERATOR’S MANUAL BEFORE ATTEMPTING TO START YOUR MOWER.

A replacement manual is available from your authorized Scag Service Dealer or by contacting Scag Power Equipment, Service Department at P.O. Box 152, Mayville, WI 53050 or contact us via the Internet at www.scag.com. The manual for this machine can be downloaded by using the model and serial number or use the contact form to make your request. Please indicate the complete model and serial number of your Scag product when requesting replacement manuals.

2.2 SIGNAL WORDS



This symbol means **“Attention! Become Alert! Your Safety is Involved!”** The symbol is used with the following signal words to attract your attention to safety messages found on the decals on the machine and throughout this manual. The message that follows the symbol contains important information about safety. To avoid injury and possible death, carefully read the message! Be sure to fully understand the causes of possible injury or death.

SIGNAL WORD:

It is a distinctive word found on the safety decals on the machine and throughout this manual that alerts the viewer to the existence and relative degree of the hazard.



The signal word “DANGER” denotes that an extremely hazardous situation exists on or near the machine that could result in high probability of death or irreparable injury if proper precautions are not taken.



The signal word “WARNING” denotes that a hazard exists on or near the machine that can result in injury or death if proper precautions are not taken.



The signal word “CAUTION” is a reminder of safety practices on or near the machine that could result in personal injury if proper precautions are not taken.

Your safety and the safety of others depends significantly upon your knowledge and understanding of all correct operating practices and procedures of this machine.

2.3 BEFORE OPERATION CONSIDERATIONS

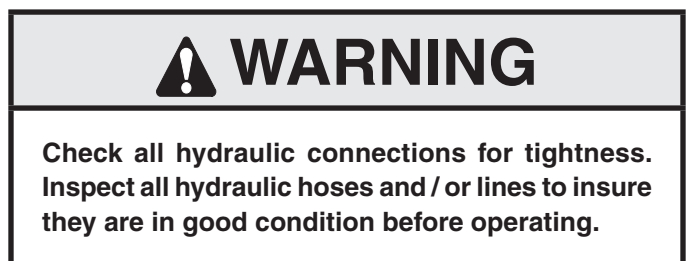

1. NEVER allow children to operate this riding mower. Do not allow adults to operate this machine without proper instructions.
2. Do not mow when children and/or others are present. Keep children out of the mowing area and in the watchful care of a responsible adult other than the operator. Be alert and turn machine off if a child enters the area.

3. DO NOT allow children to ride or play on the machine, it is not a toy.
4. Clear the area to be mowed of objects that could be picked up and thrown by the cutter blades.
5. DO NOT carry passengers.
6. DO NOT operate the machine under the influence of alcohol or drugs.
7. If the operator(s) or mechanic(s) cannot read English or Spanish, it is the owner's responsibility to explain this material to them. A Spanish decal kit is available for this model. See your local Scag Dealer.
8. DO NOT wear loose fitting clothing. Loose clothing, jewelry or long hair could get tangled in moving parts. Do not operate the machine wearing shorts; always wear adequate protective clothing including long pants. Wearing safety glasses, safety shoes and a helmet is advisable and is required by some local ordinances and insurance regulations.
10. Be sure the interlock switches are functioning correctly.
11. Fuel is flammable; handle it with care. Fill the fuel tank outdoors. Never fill it indoors. Use a funnel or spout to prevent spillage. Clean up any spillage before starting the engine.
12. DO NOT add fuel to a running or hot engine. Allow the engine to cool for several minutes before adding fuel. Never fuel indoors or inside enclosed trailers.
13. Keep flammable objects (cigarettes, matches, etc.), open flames and sparks away from the fuel tank and fuel container. Use only approved containers.
14. See Section 7.5 ENGINE FUEL SYSTEM for fueling procedure.
15. Equipment must comply with the latest requirements per SAE J137 and/or ANSI/ASAE S279 when driven on public roads.

- NOTE -

If the mower is driven on public roads, it must comply with state and local ordinances as well as SAE J137 and/or ANSI / ASAE S279 requirements. Contact your local authorities for regulations and equipment requirements.

-  **WARNING**

Always wear hearing protection. Operating this machine over prolonged periods of time can cause loss of hearing.
9. Keep the machine and attachments in good operating condition. Keep all shields and safety devices in place. If a shield, safety device or decal is defective or damaged, repair or replace it before operating the machine.

-  **WARNING**

This machine is equipped with an interlock system intended to protect the operator and others from injury. This is accomplished by preventing the engine from starting unless the deck drive is disengaged, the parking brake is on, the steering control levers are in the neutral position and the operator is in the seat. The system shuts off the engine if the operator leaves the seat with the deck drive engaged and/or the steering control levers are not in the neutral position and the parking brake is not engaged. Never operate equipment with the interlock system disconnected or malfunctioning.

16. Do not operate without the side discharge chute installed and in the down position or with an optional grass catcher or mulch plate completely installed.
17. Check the blade mounting bolts at frequent intervals for proper tightness.
18. Make sure all hydraulic fluid connections are tight and all hydraulic hoses and lines are in good condition before starting the machine.

2.4 OPERATION CONSIDERATIONS

1. Know the function of all controls and how to stop quickly.

-  **WARNING**

DO NOT operate on steep slopes. To check a slope, attempt to back up it (with the cutter deck down). If the machine can back up the slope without the wheels slipping, reduce speed and use extreme caution. Under no circumstances should the machine be operated on slopes greater than 15 degrees. See Figure 2-4, Page 7 to determine approximate slope of area to be mowed. ALWAYS FOLLOW OSHA APPROVED OPERATION.

Section 2

2. Reduce speed and exercise extreme caution on slopes and in sharp turns to prevent tipping or loss of control. Be especially cautious when changing directions on slopes.
3. Stay two cut widths away from slopes, drop offs, ditches and retaining walls.
4. To prevent tipping or loss of control, start and stop smoothly, avoid unnecessary turns and travel at reduced speed.
5. When using any attachment, never direct the discharge of material toward bystanders or allow anyone near the machine while in operation.
6. Before attempting to start the engine, with the operator in the seat, disengage power to the cutter deck, place the steering control levers in the neutral position and engage the parking brake.
7. If the mower discharge ever plugs, shut off the engine, remove the ignition key, and wait for all movement to stop before removing the obstruction.
14. Take all possible precautions when leaving the machine unattended, such as disengaging the mower, lowering the attachments, setting the parking brake, stopping the engine, and removing the key.
15. Disengage power to the attachments when transporting or when not in use.
16. The machine and attachments should be stopped and inspected for damage after striking a foreign object, and damage should be repaired before restarting and operating the machine.

 **WARNING**

DO NOT use your hand to dislodge the clogged discharge chute. Use a stick or other device to remove clogged material after the engine has stopped running and the blades have stopped turning.

 **DANGER**

DO NOT run the engine inside a building or a confined area without proper ventilation. Exhaust fumes are hazardous and contain carbon monoxide which can cause brain injury and death.

8. Be alert for holes, rocks, roots and other hidden hazards in the terrain. Keep away from any drop-offs. Beware of overhead obstructions (low limbs, etc.), underground obstacles (sprinklers, pipes, tree roots, etc.). Cautiously enter a new area. Be alert for hidden hazards.
9. Disengage power to cutter deck before backing up. Do not mow in reverse unless absolutely necessary and then only after observation of the entire area behind the mower. If you must mow in reverse, maintain a constant lookout to the rear of the machine and mow slowly.
10. DO NOT turn sharply. Use care when backing up.
11. Disengage power to cutter deck before crossing roads, walks or gravel drives.
12. Mow only in daylight or good artificial light.
13. NEVER raise the deck with the blades engaged.
17. Keep hands and feet away from cutter blades and moving parts. Contact can injure.
18. Transport the mower using a heavy duty trailer or truck. Insure the trailer or truck has all of the necessary lighting and markings as required by laws, codes, and ordinances. Secure a trailer with a safety chain.
19. Be cautious when loading and unloading onto trailers or trucks. Use only a full width ramp. Ramp angle should be no more than 15 degrees. See Figure 2-4, Page 7 to determine approximate slope of the ramp. Back up the ramp and drive down forward.
20. When transporting the mower, make sure the park brake is engaged, the steering control levers are in the neutral position, the engine is off with the key removed, and the wheels have been blocked.
21. Tie the mower down securely using straps, chains, cable, or ropes. Both front and rear straps must be directed down and outward from machine.

22. Use care when approaching blind corners, shrubs, trees, or other objects that may obscure vision.
23. NEVER leave the machine running unattended.

2.5 ROLL-OVER PROTECTION SYSTEM

WARNING

Keep the roll bar in the raised and locked position and the seat belt securely fastened during operation. Failure to do so could cause serious injury or loss of life.

This mower has been designed for good traction and stability under normal mowing conditions. However, caution must be used when traveling on slopes, especially when the grass is wet. Do not mow on wet grass. Wet grass reduces traction and steering control.

Any or all parts of the Roll-Over Protection System **MUST NOT** be removed. Failure to adhere to this guideline could result in injury or death.

WARNING

There is no roll-over protection when the roll bar is in the down position.

Lower the roll bar only when absolutely necessary.

Raise the roll bar as soon as clearance permits.

DO NOT wear the seat belt when the roll bar is in the down position.

ALWAYS wear seat belt when roll bar is in the up position.

Operate the machine smoothly, no sudden turns, starts or stops.

Check the area carefully before mowing for proper overhead clearance (i.e. branches, doorways, etc.).

DO NOT contact any overhead object with the roll bar.

Lower the roll bar only when absolutely necessary.

1. To lower the roll bar, remove the hairpin cotter pins and remove the two (2) lock pins. See Figure 2-2.
2. Lower the roll bar to the down position.
3. To raise the roll bar, lift the bar to the upright position.
4. Install the two (2) lock pins through the hole, secure with the two (2) hairpin cotter pins. See Figure 2-2.

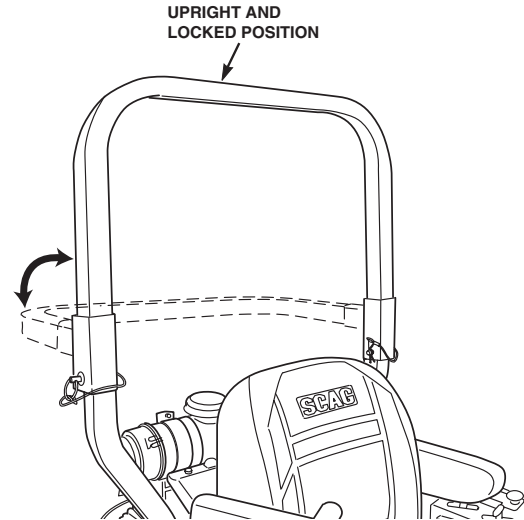

Figure 2-1. Foldable Roll-Over Protection System

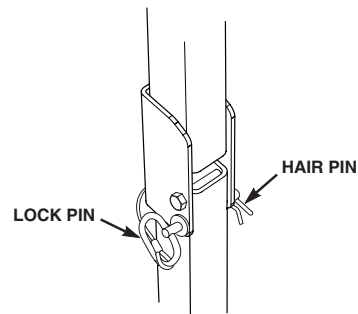

Figure 2-2. ROPS Hinge

The potential exposure of the seat belt to severe environmental conditions make it crucial to inspect the seat belt system regularly.

It is recommended that the seat belt be inspected on a daily basis for signs of damage. Any seat belt system that shows cuts, fraying, extreme or unusual wear, significant discoloration due to UV exposure, dirt or stiffness, abrasion to the seat belt webbing, or damage to the buckle, latch plate, hardware or any other obvious problem should be replaced immediately.

WARNING

Failure to properly inspect and maintain the seat belt can cause serious injury or loss of life.

1. Check the full length of the seat belt webbing for cuts, wear, fraying, dirt and stiffness. See Figure 2-3.
2. Check the seat belt webbing in areas exposed to ultra violet rays from the sun or extreme dust or dirt. If the original color of the webbing in these areas is extremely faded and/or is packed with dirt, the physical strength of this webbing may have deteriorated. If this condition exists, replace the seat belt system.
3. Check the buckle and latch for proper operation and determine if the latch plate is excessively worn, deformed, or if the buckle is damaged or cracked. See Figure 2-3.

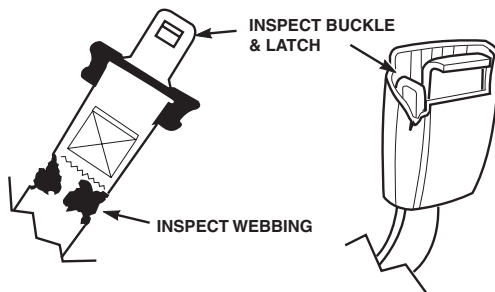

Figure 2-3. Seat Belt Inspection

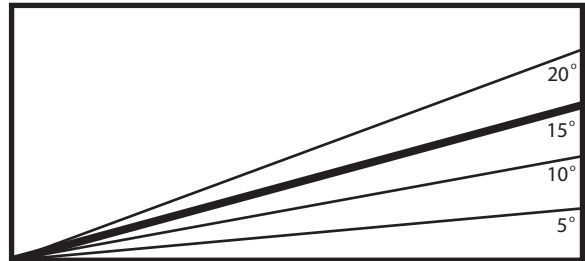

Figure 2-4. Slope Angle Graph

WARNING

Reduce speed when turning, operating on slopes, slick or wet surfaces. Allow extra distance to stop.

Stay off of slopes too steep for safe operation. To check a slope, attempt to back up it (with the cutter deck down). If the machine can not back up the slope without the wheels slipping, do not operate the machine on this slope. Under no circumstances should the machine be operated on slopes greater than 15 degrees. See Figure 2-4 to determine approximate slope.

DO NOT mow near drop-offs, ditches or embankments. The machine could suddenly roll over if a wheel goes over the edge or if the edge caves in.

Operate the machine smoothly, no sudden turns, starts or stops on a slope.

NEVER tow on slopes. The weight of the towed equipment may cause loss of traction and loss of control.

DO NOT permit untrained personnel to operate the machine.

Be cautious when loading and unloading onto trailers or trucks.

Use only a full width ramp.

Ramp angle should be no more than 15 Degrees. See Figure 2-4 to help determine approximate slope.

Back up the ramp and drive down forward.

2.6 MAINTENANCE CONSIDERATIONS & STORAGE

1. Never make adjustments to the machine with the engine running unless specifically instructed to do so. If the engine is running, keep hands, feet, and clothing away from moving parts.
2. Disengage drives, lower implement, set parking brake, stop engine and remove key or disconnect spark plug wire to prevent accidental starting of the engine when servicing or adjusting the machine. Wait for all movement to stop before adjusting, cleaning or repairing.
3. Disconnect battery or remove spark plug wire before making any repairs. Disconnect the negative terminal first and the positive last. Reconnect the positive first and the negative last.
4. Keep all nuts, bolts and screws tight, to ensure the machine is in safe working condition. Check blade mounting bolts frequently to be sure they are tight.
5. Do not change the engine governor settings or overspeed the engine. See the engine operator's manual for information on engine settings.
6. To reduce fire hazard, keep the cutting units, drives, muffler and engine free of grass, leaves, excessive grease, oil and dirt.
7. Park the machine on level ground and engage the parking brake.
8. NEVER allow untrained personnel to service the machine.
9. Use care when checking blades. Use a Blade Buddy, wrap the blade(s) or wear gloves and USE CAUTION when servicing blades. Only replace blades. NEVER straighten or weld blades.
10. Keep all parts in good working condition. Replace all worn or damaged decals.
11. Use jack stands to support components when required.
12. Carefully release pressure from components with stored energy.

WARNING

Hydraulic fluid is under high pressure and can penetrate skin causing injury. If hydraulic fluid is injected into the skin, it must be surgically removed within a few hours by a doctor or gangrene may result.

Keep body and hands away from pinholes or nozzles that eject hydraulic fluid under high pressure. Use paper or cardboard and not hands to search for leaks.

Safely relieve all pressure from the hydraulic system by placing the control levers in the neutral lock position and shutting off the engine before performing any work on the hydraulic system.

If you need service on your hydraulic system, please see your authorized Scag dealer.

13. Let the engine cool before storing.
14. DO NOT store the machine near an open flame.
15. Shut off fuel while storing or transporting.
16. DO NOT store fuel near flames or drain indoors.
17. Charge batteries in an open, well ventilated area, away from spark and flames. Unplug charger before connecting or disconnecting from battery. Wear protective clothing and use insulated tools.

2.7 USING A SPARK ARRESTOR

The engine in this machine is not equipped with a spark arrestor muffler. It is in violation of California Public Resource Code Section 4442 to use or operate this engine on or near any forest covered, brush covered or grass covered land unless the exhaust system is equipped with a spark arrestor meeting any applicable local or state laws. Other states or federal areas may have similar laws. Check with your state or local authorities for regulations pertaining to these requirements.

2.8 SPARK IGNITION SYSTEM

This spark ignition system complies with Canadian ICES-002.

Section 2

2.9 SAFETY AND INSTRUCTIONAL DECALS

	DANGER
	SPINNING BLADES
	KEEP CLEAR
	BLADE CONTACT & THROWN OBJECTS CAN INJURE

483407

	WARNING
	INSTALL BELT COVER BEFORE OPERATING MACHINE
	READ OPERATOR'S MANUAL

483402

	FORWARD	R	
	F		
		REVERSE	

481568

	WARNING
ROTATING BLADES AND BELTS	
<ul style="list-style-type: none"> * Keep hands, feet & clothing clear * Keep all guards in place * Shut off engine & disengage blade clutch before servicing * Use caution in directing discharge * Read instruction manual before operating 	
DO NOT OPERATE UNLESS GRASS CATCHER, MULCHING KIT OR DISCHARGE CHUTE IS INSTALLED	

483406

	WARNING
<p>Operation of this equipment may create sparks that can start fires around dry vegetation. A spark arrester may be required. The operator should contact local fire agencies for laws or regulations relating to fire prevention requirements.</p>	

483900

(supplied with California models only)

	WARNING
<p>Replace seat only with Scag approved seat with seat mounting provisions and Scag approved seat belts. Failure to follow these directions could result in injury or death in the event of a rollover.</p>	

483633

	DANGER
	<p>Avoid injury from burns. Shut off engine before removing fuel tank cap.</p>

483397

	DANGER
	<p>Avoid injury from burns - Shut off engine - Allow to cool several minutes - Remove cap slowly - Do not over fill</p>

Molded in Fuel Tank

START / DRIVE PROCEDURE
<ul style="list-style-type: none"> • Engage parking brake • Disengage mower deck drive • Move control handles to neutral lock position • Start engine • Release parking brake • Select forward or reverse with hydro control handles

IMPORTANT
<p>Operation on slopes can be hazardous. This machine was originally equipped with a Rollover Protection Device with a Roll Bar and Seat Belt. See your dealer if either is missing or damaged.</p>

483425

	WARNING
AVOID SERIOUS INJURY OR DEATH	
<ul style="list-style-type: none"> • Read the Operator's Manual • Operate only on slopes you can back up and never on slopes greater than 15 degrees • Solicite etiquetas en español a un distribuidor Scag • If machine stops going uphill, stop blades and back down slowly • Avoid sudden turns • Do not mow when children or others are around • Never carry children even with blades off • Look down and behind before and while backing • Keep safety devices (guards, shields, switches, etc.) in place and working • Remove objects that could be thrown by the blades • Trained operators only 	

483444

	WARNING
SERIOUS INJURY OR DEATH MAY RESULT FROM MACHINE ROLLOVER	
<p>Failure to follow these instructions could result in serious injury or death. Do not operate machine on steep slopes or near drop offs. Avoid sharp and/or quick turns. Do not exceed the machine weight rating on the ROPS. Always use the seat belt. Do not jump if machine tips while ROPS is fully extended and using seat belt. If ROPS is foldable: Keep ROPS fully extended whenever possible. WHEN ROPS MUST BE DOWN: Do not use the seat belt. Drive with extra care.</p>	

483300

IMPORTANT ADJUSTMENT PROCEDURES

READ OPERATOR'S MANUAL FOR MORE DETAILS

Check tire pressure - (Drive tires-12 psi)

- (Caster tires-25 psi)

NEUTRAL ADJUSTMENT

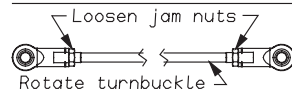

With an operator in the seat, engine running, control lever in neutral and the parking brake disengaged - adjust control linkage. Loosen jam nuts. If wheel rotates forward, adjust turnbuckle CW. If wheel rotates rearward, adjust turnbuckle CCW. Adjust until drive wheel stops turning. Tighten jam nuts. Repeat procedure until proper Neutral Adjustment is obtained.

TRACKING ADJUSTMENT

If the machine pulls to the right, adjust LH control linkage CW to slow left wheel. If the machine pulls to the left adjust RH control linkage CW to slow right wheel. Readjust neutral if necessary.

FREE WHEEL OPERATION

To move machine without running the engine, rotate both dump valves located at the LH side of the pumps CCW 1/2 turn to "freewheel" positions. Return dump valves to original position to operate the mower. Tighten to 7-10 ft-lbs.

HYDRAULIC FLUID LEVEL

Check hydraulic fluid level while fluid is cool. Fluid level should be 3" below top of filler neck. Fill with SAE 20W50 motor oil only.

IMPORTANT
<p>Do not overfill. Room for hot fluid expansion must be allowed or resulting expansion may cause leaks in the system.</p>

482709

482709

Section 3

Tire Pressure:

Front Caster.....	25 PSI
Drive	12 PSI

Fuel Tanks Dual (4 Gal. RH, 3 Gal. LH) Seamless Polyethylene Tanks with Large Opening and Fuel Cap
 Seat Padded, Thick Cushion with Extra Spring Support

Travel Speed:

Forward	0 up to 10 MPH
Reverse	0 up to 5 MPH

-NOTE- The machine will travel up to 10 mph for transport purposes. For best cutting performance the forward travel speed should be adjusted depending upon the cutting conditions.

3.4 CUTTER DECK

Type Floating, Adjustable, Anti-Scalping, Hybrid Design Combines Out-Front and Belly-Mount Designs
 Construction Tri-plate deck construction

Top of deck consists of three steel plates totaling nearly 1/2" of steel, 7-gauge (3/16") deck skirt.

True Cutting Width:

48V	48" (122.0 cm)
52V	52" (132.0 cm)
61V	61" (154.94 cm)

Cutting Height Adjustment.....Foot-Operated Lever Adjustment from Operator's Seat, 1.00" to 5.5" in 1/4" increments

Cutter Blades..... 0.197 in. Thick, Milled Edge, Wear Resistant Marbain™

Blade Engagement..... Electric Blade Engagement Clutch with Control Panel Switch
 Connected to the Cutter Deck through a Belt.

Discharge Opening..... Extra Wide Discharge Opening with Spring-Loaded Discharge Chute and Turbo Baffle

Discharge Chute..... Black, Polypropylene (Plastic), Flexible

Spindles..... Heavy-Duty 1-1/8" Top Dimension Spindle Shaft, Cast Housing, Taper Roller Bearing,
 Low Maintenance with Top Access Grease Fitting and Grease Overfill Relief Poppet

Spindle Pulleys..... Split Steel with Easily Removed Taper Hubs

Cutter Deck Belts..... B-section and Cogged Type with Kevlar Cord. Self-Adjusting, Self-Tightening

Electric Clutch Type Ogura Heavy Duty PTO Clutch Brake

3.5 HYDRAULIC SYSTEM

Hydraulic Oil Filter 10 Micron Spin-on Element Type

Hydraulic Reservoir Nylon; 2-1/2 Quart Capacity

3.6 WEIGHTS AND DIMENSIONS

	48V	52V	61V
Length.....	80"	80"	80"
Tracking Width	46.5"	46.5"	46.5"
Overall Width w/chute down	60.5"	64.5"	73.5"
Overall Width w/chute up.....	49"	53"	62"
Overall Height w/ROPS (up on Folding Models)	66"	66"	66"
Overall Height w/ROPS down (Folding Models)	54"	54"	54"
Operating Weight w/ROPS	1050#	1100#	1150#

3.7 PRODUCTIVITY

	48V	52V	61V
Cutting Width	48"	52"	61"
Acres Per Day.....	18.6	20.2	23.7

The preceding chart will aid you in determining how many acres your Scag mower will cut per day. The chart is an estimate based on 8 hours per day cutting time at 6 MPH with a 20% allowance for overlap and turns.

OPERATING INSTRUCTIONS

CAUTION

Do not attempt to operate this mower unless you have read this manual. Learn the location and purpose of all controls and instruments before you operate this mower.

4.1 CONTROLS AND INSTRUMENT IDENTIFICATION

Before operating the mower, familiarize yourself with all mower and engine controls. Knowing the location, function and operation of these controls is important for safe and efficient operation of the mower.

1. **Ignition Switch (Figure 4-1).** The ignition switch is used to start the engine and has three positions; OFF, ON, and START.

2. **Mower Deck Switch (Figure 4-1).** Used to engage and disengage the mower drive system. Pulling up on the switch will engage the deck drive. Pushing down on the switch will disengage the deck drive.
3. **Engine Choke Control (Figure 4-1).** Used to start a cold engine.
4. **Engine Throttle Control (Figure 4-1).** Used to control the engine speed. Pushing the lever forward increases engine speed. Pulling the lever back decreases engine speed. Full back position is the IDLE position. Full forward is the cutting position.
5. **Hourmeter (Figure 4-1).** Indicates the number of hours the engine has been operated. It only operates when the engine is running. Has preset maintenance reminders for engine and hydraulic system oil changes. Will start flashing scheduled maintenance 2 hours before preset time and continue flashing until 2 hours after. Automatically resets.

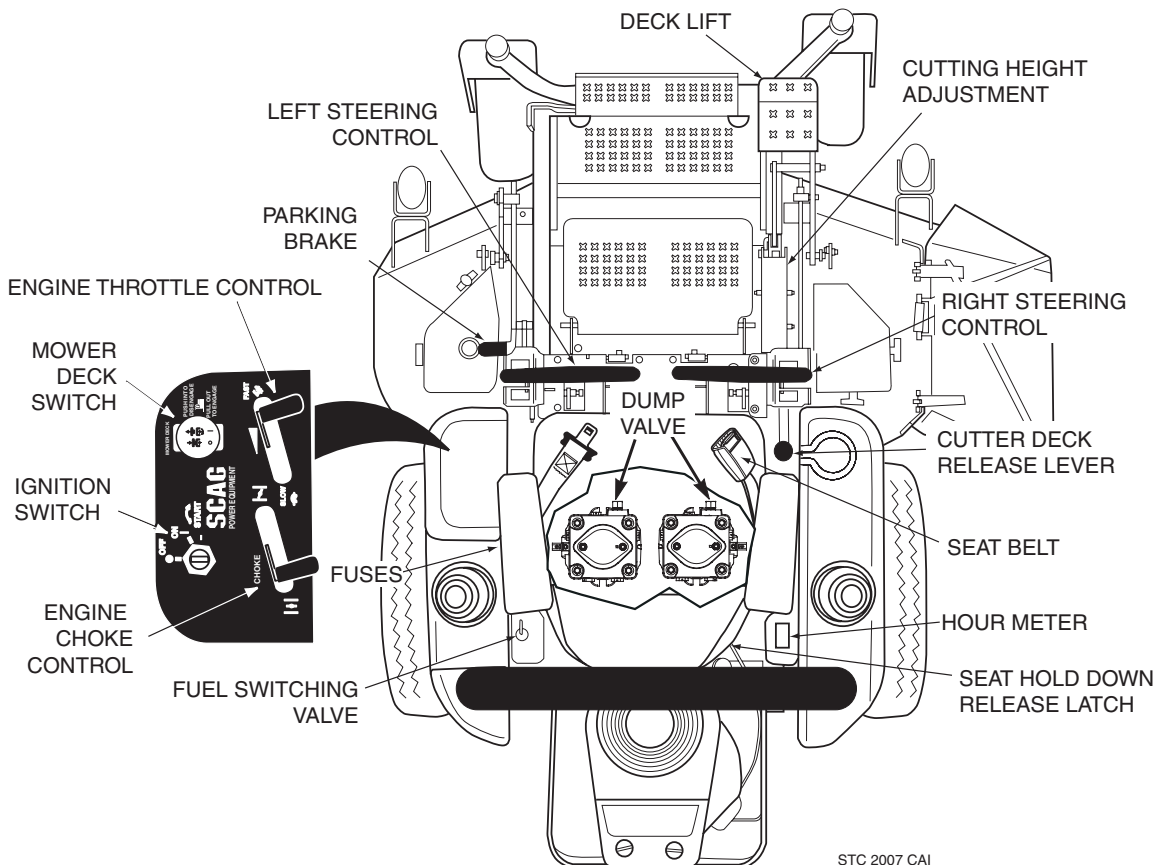

Figure 4-1. Controls and Instruments

Section 4

6. **Fuse Holders (Figure 4-1).** Two 20-amp fuses protect the mower's electrical system. To replace fuses, pull fuse out of the socket and install a new fuse.
7. **Left Steering Control (Figure 4-1).** Used to control the mower's left wheel when traveling forward or reverse.
8. **Right Steering Control (Figure 4-1).** Used to control the mower's right wheel when traveling forward or reverse.
9. **Parking Brake Control (Figure 4-1).** Used to engage and disengage the parking brakes. Pull the lever back to engage the parking brakes. Push the lever forward to disengage the parking brakes.
10. **Fuel Switching Valve (Figure 4-1).** Located on the left side of the machine. Used to shut off fuel supply to the engine and change fuel supply between the fuel tanks. Rotate the valve counter clockwise to supply fuel from the tank on the left side only. Rotate the valve clockwise to supply fuel from the tank on the right side only.
11. **Dump Valve Control Levers (Figure 4-2).** Located on the hydraulic pumps, used to "free-wheel" the mower. Rotating the levers clockwise until they stop allows the unit to move under hydraulic power. The levers must be in this position and torqued to 10ft/lbs during operation of the mower. Rotating the levers counter-clockwise allows the mower to be moved by hand (free-wheeling).

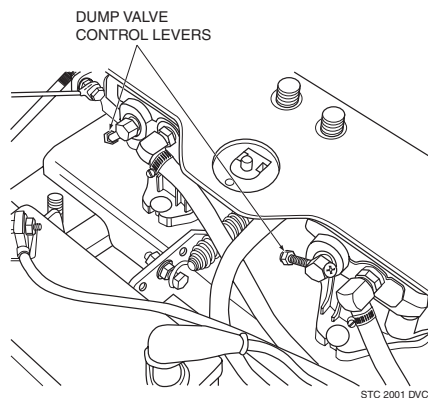

Figure 4-2. Dump Valve Control

12. **Deck Lift Foot Lever (Figure 4-1).** Used to raise and lower the cutter deck. Push full forward to lock in the transport position.
13. **Cutting Height Adjustment (Figure 4-1).** Used to set the cutter deck at the desired cutting height.

14. **Deck Release Lever (Figure 4-1).** Used to lock the cutter deck in the transport position. Push the foot pedal forward and pull back on the release lever to release the cutter deck for normal mowing.
15. **Seat Belt (Figure 4-1).** Used to secure the operator. Seat belt must be worn at all times when the ROPS is in the upright and locked position.
16. **Seat Hold Down Release Latch (Figure 4-1).** Located behind the seat. Used to secure the seat in the operator's position. Release the latch to gain access under the seat.

4.2 SAFETY INTERLOCK SYSTEM

The mower is equipped with a safety interlock system that prevents the engine from starting unless the deck drive is disengaged, the parking brake is engaged, the steering control levers are in the neutral position and the operator is in the seat. The interlock system shuts off the engine if the operator leaves the seat with the steering control levers not in the neutral position and/or the cutter blades engaged and the parking brake not engaged.

WARNING

Never operate the mower with the interlock system disconnected or malfunctioning. Do not disengage or bypass any switch; injury to yourself and others or property damage could result.

4.3 INITIAL RUN-IN PROCEDURES

FIRST DAY OF USE OR APPROXIMATELY 20 HOURS

1. Check all belts for proper alignment and wear at 2, 4 and 8 hours.
2. Change the engine oil and oil filter after the first 20 hours of operation. (See Section 7.4.)
3. Check hydraulic oil level in reservoir. (See Section 7.3.)
4. Check for loose hardware. Tighten as needed.
5. Check interlock system for proper operation. (See Section 4.2.)
6. Check tire pressure. Adjust pressure if necessary. (See Section 7.10.)

4.4 STARTING THE ENGINE

CAUTION

DO NOT USE STARTING FLUIDS. Use of starting fluids in the air intake system may be potentially explosive or cause a “runaway” engine condition that could result in engine damage and/or personal injury.

1. Be sure the fuel shutoff valve, located behind the operator's seat, is completely open. (See Section 7.5.)
2. Secure the ROPS in the upright and locked position.
3. Sit in the operator's seat, fasten seat belt and place the steering control levers in the neutral position.
4. Engage the parking brake.
5. Place the PTO switch in the disengaged position.
6. If the engine is cold, choke the engine as needed.
7. Move the engine throttle control to about half engine speed.
8. Turn the ignition key to the START position and release the key as soon as the engine starts. Do not hold the key in the START position for more than 15 seconds at a time. Allow at least 60 seconds between each cranking attempt to prevent overheating of the starter motor. Prolonged cranking can damage the starter motor and shorten battery life.
9. Allow engine to warm before operating the mower.

4.5 GROUND TRAVEL AND STEERING

- IMPORTANT -

If you are not familiar with the operation of a machine with lever steering and/or hydrostatic transmissions, the steering and ground speed operations should be learned and practiced in an open area, away from buildings, fences, or obstructions.

Learn the operation on flat ground before operating on slopes.

Start practicing with a slow engine speed and slow forward travel.

Learn to feather the steering controls to obtain a smooth operating action.

Practice operating the mower until you are comfortable with the controls before proceeding to mow.

FORWARD TRAVEL

To travel forward with the mower, disengage the parking brake, pull levers inward out of the neutral lock position and slowly push the steering control levers forward an equal distance. The further the steering control levers are pushed forward the greater the forward speed will be. To increase the speed, push the steering control levers further forward and to decrease the speed, pull the steering control levers back.

To stop the forward travel, pull the steering control levers back to the neutral position.

To steer the mower left while traveling forward, pull the left steering lever back. The further the lever is pulled back, the quicker the mower will turn left.

To steer the mower right while traveling forward, pull the right steering control lever back. The further the lever is pulled back, the quicker the mower will turn right.

- NOTE -

Smooth operation of the steering levers will produce smooth mower operation. While learning the operation of the steering controls, keep the travel speed low.

- IMPORTANT -

Do not travel forward over a curb. The mower will hang up on the curb. Raise the deck and travel backwards over the curb at a 45 degree angle. (See Figure 4-1 items 12-14 for cutter deck raising description.)

REVERSE TRAVEL

⚠ CAUTION

Disengage power to the mower before backing up. Do not mow in reverse unless absolutely necessary and then only after observation of the entire area behind the mower.

⚠ CAUTION

Before backing up, observe the rear for persons and obstructions. Clear the area before backing up. Possible injury or property damage could occur.

To travel in reverse, pull levers inward out of the neutral lock position and pull both handles back. Keep the travel speed low while traveling in reverse.

- NOTE -

The mower may not travel straight in reverse. Slight adjustments may need to be made using the steering controls.

To steer left while traveling in reverse, allow the left steering control lever to move forward. The further the control is allowed to move forward, the quicker the mower will turn left.

To steer right while traveling in reverse, allow the right steering control lever to move forward. The further the control is allowed to move forward, the quicker the mower will turn right.

To stop the reverse travel, allow the steering control levers to return to the neutral position. If the mower is to be parked, place the handles in the neutral lock position and engage the parking brake.

4.6 ENGAGING THE DECK DRIVE (CUTTER BLADES)

1. Set the throttle at about 3/4 speed. Do not attempt to engage the deck drive at high speed as this shortens the electric clutch life — use only moderate engine speed when engaging the deck drive.
2. Engage the deck drive by pulling out on the yellow switch, located on the instrument panel, to the engage position. See Figure 4-3.

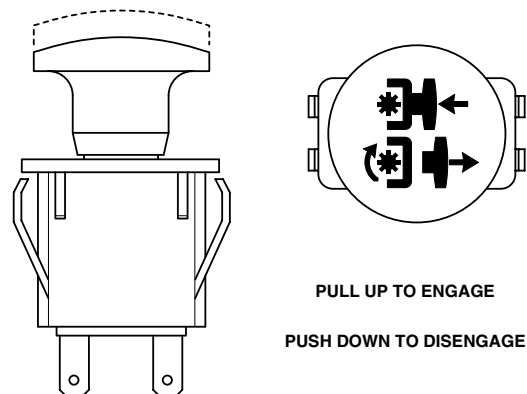

390S0138

Figure 4-3. Cutter Engage Switch

- NOTE -

A squealing noise may be heard when engaging or disengaging the deck drive. It is caused by the electric clutch plates meshing as the mower comes up to speed. This is normal.

3. To disengage the deck drive, push the switch in to the disengage position.
4. Always operate the engine at full throttle to properly maintain cutting speed. If the engine starts to lug down, reduce the forward speed and allow the engine to operate at maximum RPM.

4.7 HILLSIDE OPERATION

WARNING

DO NOT operate on steep slopes. To check a slope, attempt to back up it (with the cutter deck down). If the machine can back up the slope without the wheels slipping, reduce speed and use extreme caution. Under no circumstances should the machine be operated on slopes greater than 15 degrees. See Figure 2-4, Page 7 to help determine approximate slope of area to be mowed. ALWAYS FOLLOW OSHA APPROVED OPERATION.

1. This mower has been designed for good traction and stability under normal mowing conditions. However, caution must be used when traveling on slopes, especially when the grass is wet. Wet grass reduces traction and steering control. The Roll-Over Protection System is standard equipment for this machine. See Section 2.5, page 6 of this manual for further details.
2. To prevent tipping or loss of control, do not start or stop suddenly, avoid unnecessary turns and travel at reduced speed. If tires lose traction, disengage blades and proceed slowly off the slope.
3. Avoid sudden starts when mowing uphill. Sudden starts may cause the machine to tip backwards.
4. Loss of traction may occur when traveling down hill. Weight transfers to the front of the machine and may cause the drive wheels to slip causing loss of braking or steering.
5. Keep tires properly inflated.

4.8 PARKING THE MOWER

1. Park the machine on a flat, level surface only. Do not park the machine on an incline.
2. Place the steering control levers in the neutral position.
3. Disengage the cutter blades.
4. Slow the engine to idle speed.
5. Engage the parking brake.
6. Turn the ignition key to the OFF position and remove the key.

4.9 AFTER OPERATION

1. Wash the entire mower after each use. Do not use high pressure spray or direct the spray onto electrical components.

- IMPORTANT -

Do not wash a hot or running engine. Cold water will damage the engine. Use compressed air to clean the engine if it is hot.

2. Keep the entire mower clean to inhibit serious heat damage to the engine or hydraulic oil circuit.
3. Check the drive belts for proper alignment and any signs of wear. Correct and adjust if necessary.

DANGER

To avoid injury from burns, allow the mower to cool before removing the fuel tank cap and refueling.

4. After the mower has cooled down, fill the fuel tank with fresh, clean fuel at the end of every day of operation. See Engine Owner's Manual for proper octane requirements.
5. Check the tire pressure. Adjust pressure if necessary.

4.10 REMOVING CLOGGED MATERIAL

DANGER

ROTATING BLADES

NEVER PUT YOUR HANDS INTO THE DISCHARGE CHUTE FOR ANY REASON!

Shut off the engine and remove the key and only then use a stick or similar object to remove material if clogging has occurred.

1. If the discharge chute becomes clogged, shut off the engine and remove the ignition key. Using a stick or similar item, dislodge the clogged material. Then resume normal mowing.

Section 4

4.11 MOVING MOWER WITH ENGINE STOPPED

To “free-wheel” or move the mower around without the engine running, rotate the dump valve levers counter-clockwise. See Figure 4-4. Disengage the parking brake and move the mower by hand. When the machine is in the desired position, engage the parking brake and rotate the levers clockwise until they stop. The dump valve levers must be returned to the DRIVE position and torqued to 10ft/lbs to drive the mower.

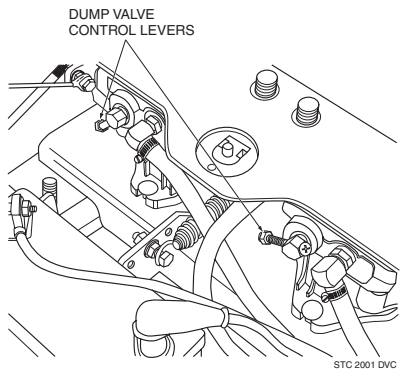

Figure 4-4. Dump Valve Control

4.12 RECOMMENDATIONS FOR MOWING

1. Do not mow with dull blades. A dull blade will tear grass, resulting in poor lawn appearance and reduced mowing power.

WARNING

DO NOT operate without Discharge Chute, Mulching Kit, or entire Grass Catcher properly installed.

2. The discharge chute must not be removed and must be kept in the lowest position to deflect grass clippings and thrown objects downward. Direct the side discharge away from sidewalks or streets to minimize cleanup of clippings. When mowing close to obstacles, direct the discharge away from the obstacles to reduce the chance of property damage by thrown objects.
3. Cut grass when it is dry and not too tall. Do not cut grass too short (cut off 1/3 or less of existing grass for best appearance). Mow frequently.

4. Keep mower and discharge chute clean.
5. When mowing wet or tall grass, mow the grass twice. Raise the mower to the highest setting for the first pass and then make a second pass to the desired height.
6. Use a slow travel speed for trimming purposes.
7. Operate the engine at full throttle for best cutting. Mowing with a lower RPM causes the mower to tear the grass. The engine is designed to be operated at full speed.
8. Use the alternate stripe pattern for best lawn appearance. Vary the direction of the stripe each time the grass is mowed to avoid wear patterns in the grass.

4.13 ADJUSTING CUTTING HEIGHT

The mower deck can be adjusted from a height of 1 inch to 5 inches at 1/4-inch intervals. To adjust the cutting height:

WARNING

DO NOT adjust the cutting height with the mower blades rotating. Disengage the power to the cutter blades and then adjust cutting height.

1. Disengage the power to the cutter blades.
2. Push the cutting height adjustment foot pedal all the way forward using your right foot until it locks in place. See Figure 4-5.

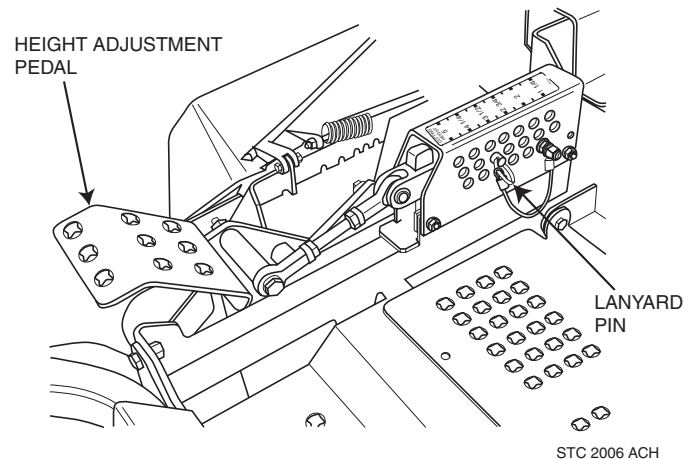

Figure 4-5. Adjusting Cutting Height

3. Insert the lanyard pin into the cutting height index at the desired cutting height. Push forward on the deck lift foot lever, hold in place and pull back on the deck release lever. See Figure 4-6. Slowly release the foot pedal. A deck height decal is located on the cutting height index as an aid in adjusting the deck to the desired height. See Figure 4-5.

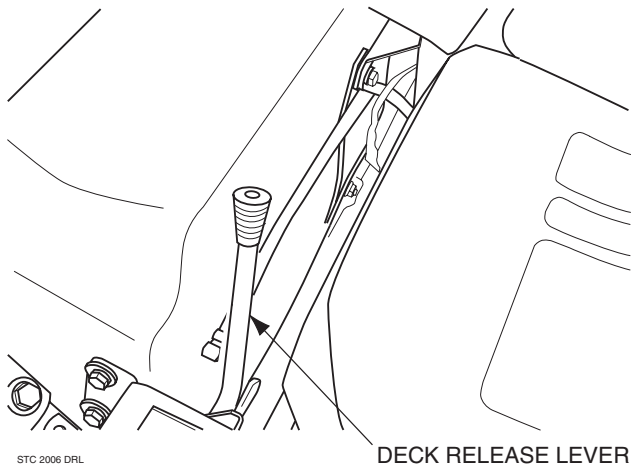
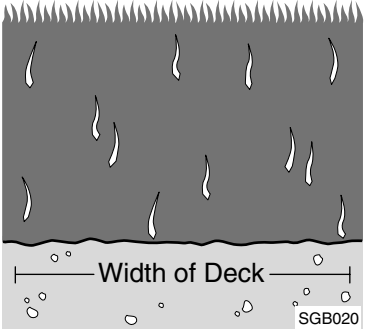
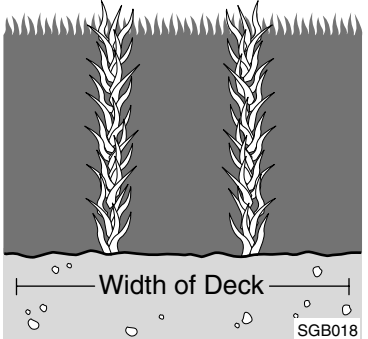
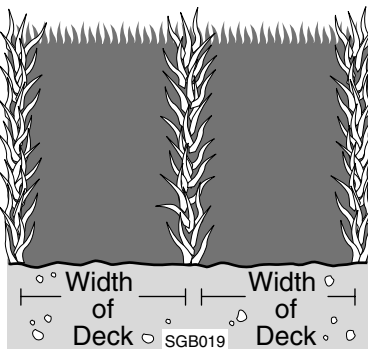

Figure 4-6. Deck Release Lever

4.14 TOWING (OPTIONAL HITCH ACCESSORY)

1. NEVER allow children or others in or on towed equipment.
2. Tow only with a machine that has a hitch designed for towing. Do not attach towed equipment except at the hitch point.
3. Follow manufacturer's recommendations for weight limit for towed equipment. 250/lbs. maximum towing weight.
4. NEVER tow on slopes. The weight of the towed equipment may cause loss of traction and loss of control.
5. Travel slowly and allow extra distance to stop.
6. Zero-turning with a trailer attached could cause damage to the trailer or mower.

TROUBLESHOOTING CUTTING CONDITIONS

CONDITION	CAUSE	CURE
<p>STRINGERS - OCCASIONAL BLADES OF UNCUT GRASS</p> 	Low engine RPM	Run engine at full RPM
	Ground speed too fast	Slow speed to adjust for conditions
	Wet grass	Cut grass after it has dried out
	Dull blades, incorrect sharpening	Sharpen blades
	Deck plugged, grass accumulation	Clean underside of deck
	Belts slipping	Adjust belt tension
<p>STREAKING - STRIPS OF UNCUT GRASS IN CUTTING PATH</p> 	Dull, worn blades	Sharpen blades
	Incorrect blade sharpening	Sharpen blades
	Low engine RPM	Run engine at full RPM
	Belt slipping	Adjust belt tension
	Deck plugged, grass accumulation	Clean underside of deck
	Ground speed too fast	Slow speed to adjust for conditions
	Wet grass	Cut grass after it has dried out
	Bent blades	Replace blades
<p>STREAKING - STRIPS OF UNCUT GRASS BETWEEN CUTTING PATHS</p> 	Not enough overlapping between rows	Increase the overlap of each pass

TROUBLESHOOTING CUTTING CONDITIONS (CONT'D)

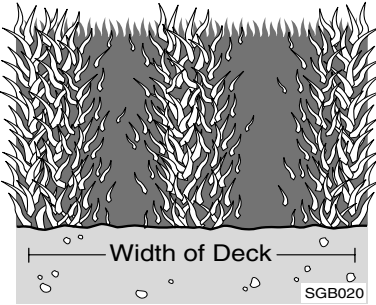
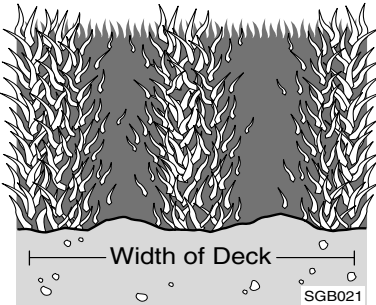
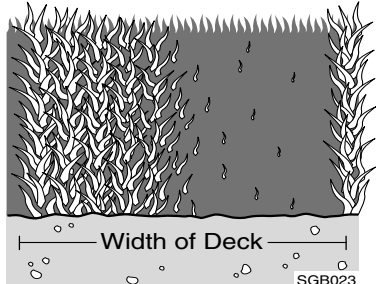
CONDITION	CAUSE	CURE
<p>UNEVEN CUT ON FLAT GROUND - WAVY HIGH-LOW APPEARANCE, SCALLOPED CUT, OR ROUGH CONTOUR</p>  <p style="text-align: right; font-size: small;">SGB020</p>	Lift worn from blade	Replace blade
	Blade upside down	Mount with cutting edge toward ground
	Deck plugged, grass accumulation	Clean underside of deck
	Too much blade angle (deck pitch)	Adjust pitch and level
	Deck mounted improperly	See your authorized SCAG dealer
	Bent spindle area	See your authorized SCAG dealer
	Dull blade	Sharpen blade
<p>UNEVEN CUT ON UNEVEN GROUND-WAVY APPEARANCE, HIGH-LOW SCALLOPED CUT, OR ROUGH CONTOUR</p>  <p style="text-align: right; font-size: small;">SGB021</p>	Uneven ground	May need to reduce ground speed, raise cutting height, and/or change direction of cut
<p>SLOPING RIDGE ACROSS WIDTH OF CUTTING PATH</p>  <p style="text-align: right; font-size: small;">SGB023</p>	Tire pressures not equal	Check and adjust tire pressure
	Wheels uneven	Check and adjust tire pressure
	Deck mounted incorrectly	See your authorized SCAG dealer
	Deck not level side-to-side	Check for level and correct

TROUBLESHOOTING CUTTING CONDITIONS (CONT'D)

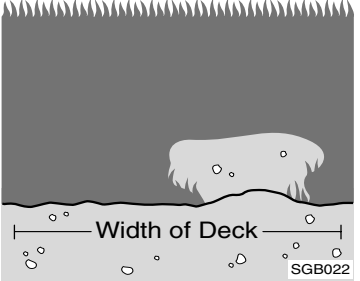
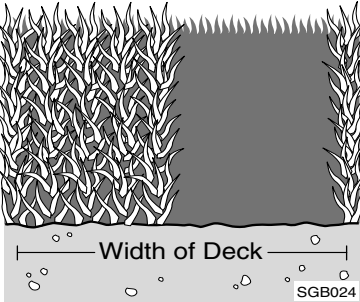
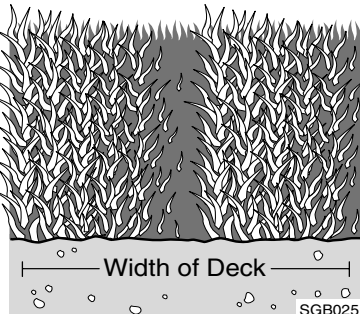
CONDITION	CAUSE	CURE
<p>SCALPING - BLADES HITTING DIRT OR CUTTING VERY CLOSE TO THE GROUND</p> 	Low tire pressures	Check and adjust pressures
	Ground speed too fast	Slow speed to adjust for conditions
	Cutting too low	May need to reduce ground speed, raise cutting height, change direction of cut, and/or change pitch and level
	Rough terrain	May need to reduce ground speed, raise cutting height, and/or change direction of cut
	Ground speed too fast	Slow speed to adjust for conditions
	Wet grass	Cut grass after it has dried out
<p>STEP CUT - RIDGE IN CENTER OF CUTTING PATH</p> 	Blades not mounted evenly	Adjust pitch and level
	Bent blade	Replace blade
	Internal spindle failure	See your authorized SCAG dealer
	Mounting of spindle incorrect	See your authorized SCAG dealer
<p>SLOPE CUT - SLOPING RIDGES ACROSS WIDTH OF CUTTING PATH</p> 	Bent spindle mounting area	See your authorized SCAG dealer
	Internal spindle failure	See your authorized SCAG dealer
	Bent deck housing	See your authorized SCAG dealer

ADJUSTMENTS

6.1 PARKING BRAKE ADJUSTMENT

WARNING

Do not operate the mower if the parking brake is not operable. Possible severe injury could result.

The parking brake linkage should be adjusted whenever the parking brake lever is placed in the “ENGAGE” position and the parking brake will allow the mower to move. If the following procedures do not allow you to engage the parking brake properly, contact your Scag dealer for further brake adjustments.

1. Position a floor jack under the rear of the machine. Raise the machine and support it to prevent it from falling. Block the caster wheels to prevent the machine from moving. Remove the drive wheels.
2. With the brake in the engaged position, check the distance between the lower nut on the brake actuator rod and the brake actuator lever on the LH side of the machine. The distance should be 1/8". See Figure 6-2.
3. If the distance is not at the specified measurement, loosen the jam nut at the clevis on the top of the brake actuator rod. See Figure 6-2.
4. Turn the bolt at the bottom of the brake actuator lever until the 1/8" measurement is achieved and tighten the jam nut at the clevis on the brake actuator rod. See Figure 6-2. If the 1/8" measurement can not be achieved by adjusting the brake actuator rod, adjust the brake control rod. Adjust by loosening the jam nuts at both ends of the brake control rod and turning the rod until the proper distance is achieved. See Figure 6-1.
5. Repeat steps 2-4 on the RH side of the machine.
6. Replace the drive wheels and test the brake.

- NOTE -

If this procedure does not achieve proper brake adjustment, please contact your authorized Scag dealer.

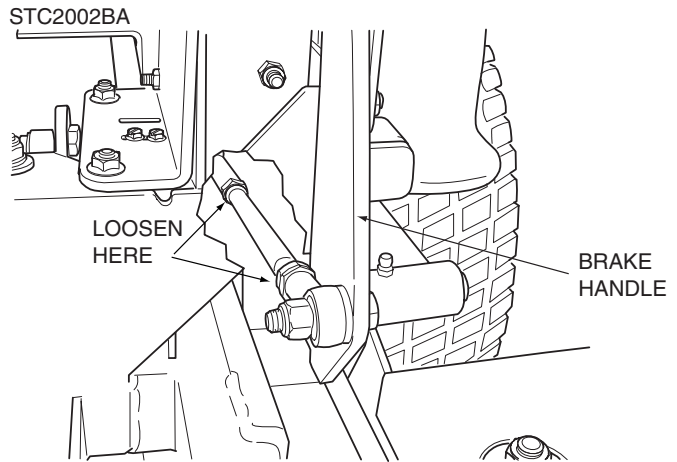

Figure 6-1. Brake Adjustment

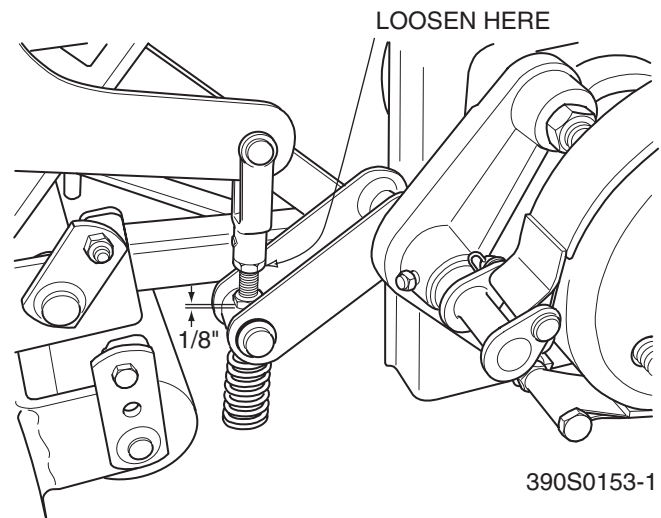

Figure 6-2. Brake Rod Adjustment

6.2 TRAVEL ADJUSTMENTS

Neutral or tracking adjustments will need to be made if:

- A. The steering control levers are in the neutral position and the machine creeps forward or backward. (Neutral Adjustment, See Page 23).
- B. The steering control levers are in the full forward position and the mower pulls to one side or the other when traveling in a forward direction. (Tracking Adjustment, See Page 23).

Section 6

NEUTRAL ADJUSTMENT

1. Be sure the dump valve levers are in the run position and the steering control levers are in the neutral lock position.
2. With an operator in the seat, start the engine and disengage the parking brake.
3. Run the engine at full operating speed and check if the machine creeps forward or backwards.
4. Adjust the RH wheel by loosening the jam nuts on the steering control rod and turning the rod until the drive wheel turns in the forward direction. Turn the rod back until the drive wheel stops moving. Turn the rod an additional 1/2 turn. See Figure 6-3.

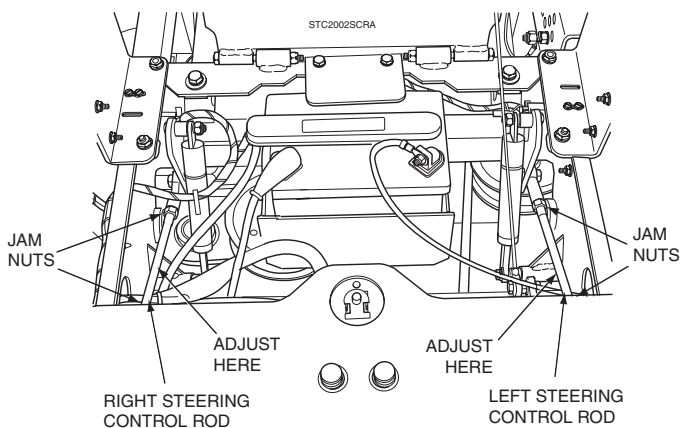

Figure 6-3. Steering Control Rod Adjustment

5. Tighten the jam nuts and repeat for the LH wheel. See Figure 6-3.
6. Actuate the steering control levers forward and reverse several times and return them to the neutral position.
7. Check that the drive wheels remained in neutral and readjust if necessary.
8. Check that the steering control levers hit the stop before the pumps reach full stroke. Adjust as needed.

TRACKING ADJUSTMENT

⚠ CAUTION

Stop the engine and remove the key from the ignition before making any adjustments. Wait for all moving parts to come to a complete stop before beginning work.

⚠ CAUTION

The engine and drive unit can get hot during operation causing burn injuries. Allow engine and drive components to cool before making any adjustments.

- NOTE -

Before proceeding with this adjustment, be sure that the caster wheels turn plus pivot freely and that the tire pressure in the drive wheels is correct. If the tire pressure is not correct, the machine will pull to the side with the lower pressure.

1. If at full speed the mower pulls right, it is an indication that the left wheel is turning faster than the right wheel. To adjust this condition, proceed as follows:

A. Stop the machine and place the steering control levers in the neutral position. Loosen the lock nuts securing the ball joints at each end of the LH steering control rod. Rotate the control rod to lengthen the rod and tighten the lock nuts. This will cause the control rod to stroke the LH pump less, slowing down the LH wheel. See Figure 6-3.

- NOTE -

If after making the adjustment as outlined in step 1A, the machine creeps forward or backward, perform the neutral adjustment. See Neutral Adjustment on page 23.

2. If at full speed the mower pulls left, it is an indication that the right wheel is turning faster than the left wheel. To adjust this condition, proceed as follows:

A. Stop the machine and place the steering control levers in the neutral position. Loosen the lock nuts securing the ball joints at each end of the RH steering control rod. Rotate the control rod to lengthen the rod and tighten the lock nuts. This will cause the control rod to stroke the RH pump less, slowing down the RH wheel. See Figure 6-3.

- NOTE -

If after making the adjustment as outlined in step 2A, the machine creeps forward or backward, perform the neutral adjustment. See Neutral Adjustment on page 23.

6.3 THROTTLE CONTROL AND CHOKE ADJUSTMENTS

These adjustments must be performed by your Scag dealer to ensure proper and efficient running of the engine. Should either need adjustment, contact your authorized Scag service center.

6.4 BELT ADJUSTMENT

⚠ WARNING

Before removing any guards, shut the engine off and remove the ignition key.

All drive belts are spring loaded and self-tensioning, however after the first 2, 4, 8 and 10 hours of operation, the belts should be checked for proper alignment and wear. Thereafter, check the belts after every 40 hours of operation or weekly, whichever occurs first.

6.5 BELT ALIGNMENT

Belt alignment is important for proper performance of your Scag mower. If you experience frequent belt wear or breakage, see your authorized Scag service center for belt adjustment.

6.6 CUTTER DECK ADJUSTMENTS

Cutter deck level, pitch and height are set at the factory. However, if these adjustments should ever need to be made, the following procedures will aid in obtaining the proper cutter deck adjustment.

- NOTE -

Before proceeding with the cutter deck adjustments, be sure that all tires are properly inflated.

CUTTER DECK LEVEL

The cutter deck should be level from side-to-side for proper cutting performance. To check for level, be sure that the mower is on a flat, level surface, the tires are properly inflated and the cutter deck is set at the most common cutting height that you will use. On the RH side of the machine, check the distance from the bottom of the cutter deck to the floor. Next check the distance from the bottom of the cutter deck to the floor on the LH side of the machine. Both measurements should be the same. If the two measurements are different, the cutter deck level must be adjusted as follows:

1. On the front LH side of the cutter deck locate the cutter deck level adjusting bracket. See Figure 6-4.

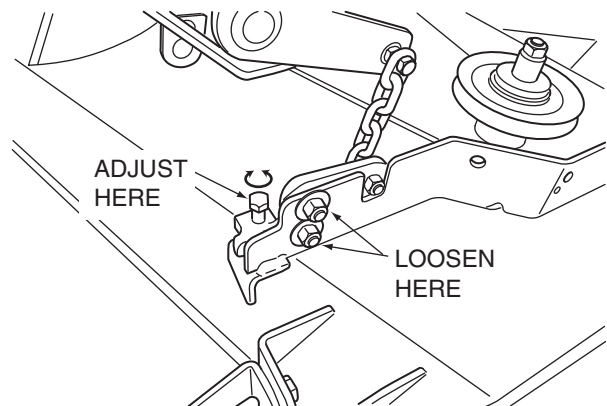

Figure 6-4. Cutter Deck Level Adjustment

2. Loosen the two (2) elastic stop nuts. Adjust the bolt up or down on the adjustment bracket to adjust the cutter deck until the distance from the bottom of the cutter deck to the floor is the same as the measurement on the RH side of the machine.
3. Tighten the two (2) elastic stop nuts to secure the cutter deck in the proper position.

Section 6

CUTTER DECK PITCH

The pitch of the cutter deck should be equal between the front and rear of the cutter deck for proper cutting performance. To check for proper deck pitch, be sure that the mower is on a flat, level surface and the tires are properly inflated.

Check the distance from the top of the cutter deck to the floor at the rear RH side of the cutter deck directly behind the cutter deck hanging chains. Next check the distance from the top of the cutter deck to the floor at the front RH side of the cutter deck directly in front of the cutter deck hanging chains. The measurement at the front of the cutter deck should be the same as the rear of the deck. Make these measurements at the LH side of the cutter deck also. If the measurement at the front of the deck is not the same, the cutter deck pitch must be adjusted as follows:

1. Loosen the jam nut on both adjusting rods. See Figure 6-5.

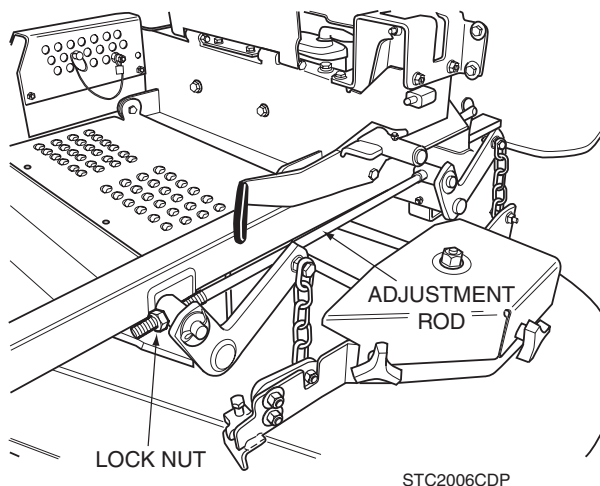

Figure 6-5. Cutter Deck Level Adjustment

2. Using an adjustable jaw pliers, turn the adjusting rods on the non-threaded portion of the rod until the deck is equal front to back on both the RH and the LH side of the cutter deck. Tighten both lock nuts.

- NOTE -

To prevent the cutter deck from teetering, all four (4) cutter deck hanging chains must have tension on them. If all four chains do not have tension on them and the deck teeters, you must readjust the cutter deck as outlined in the procedures above. All measurements should be taken from the top edge of the deck as the Velocity Plus decks have an uneven bottom edge.

CUTTER DECK HEIGHT

The cutter deck height adjustment is made to ensure that the cutter deck is cutting at the height indicated on the cutting height index gauge. To check for proper deck height, be sure that the mower is on a flat, level surface and the tires are properly inflated.

1. Place the cutter deck in the transport position. Loosen the jam nuts on both ends of the deck height control rod. See Figure 6-6.

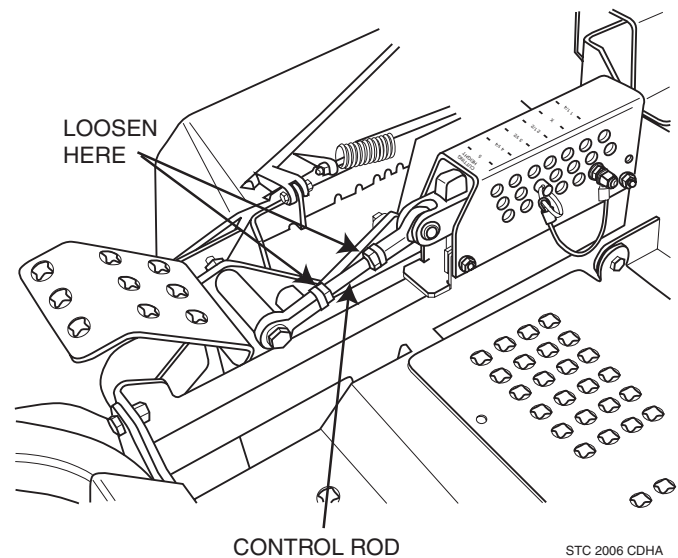

Figure 6-6. Cutter Deck Height Adjustment

2. Turn the control rod (See Figure 6-6) until there is a 1/4" space between the rear deck stop and the top of the cutter deck. See Figure 6-7. Tighten the jam nuts on the control rod.

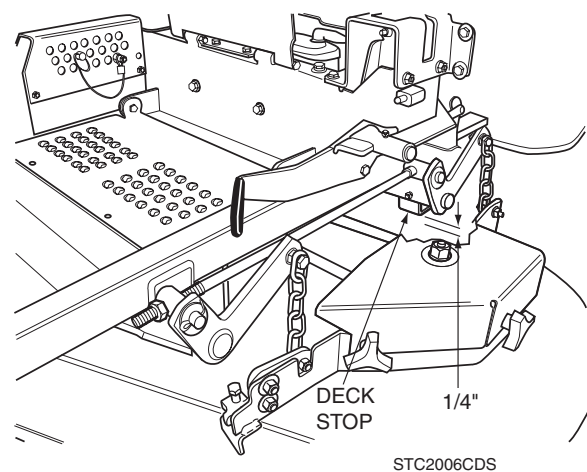

Figure 6-7. Cutter Deck Stop

3. Check the cutter deck cutting height by placing the lanyard pin in the 3" position on the cutting height index. Release the deck from the transport position and allow the deck to move to the 3" cutting height position.
4. Check the measurement from the floor to the cutter blade tip. If the measurement is not at 3", an adjustment can be made using the deck height control rod. See Figure 6-6.

- NOTE -

If an adjustment had to be made, be sure that the cutter deck can easily be locked into the transport position.

B. 4" (factory setting), 4-1/4" or 4-1/2" Position - (See Figure 6-9). For general purpose cutting. This gives the best mix of cutting performance in all types of grass.

C. 4-3/4" or 5-1/4" Position - (See Figure 6-9). Placing the baffle in either the 4-3/4" or 5-1/4" setting will enhance fall cutting (leaf pickup) and reduce cutter deck "blowout".

To adjust the Custom-Cut Baffle height:

1. Place the cutter deck in the transport position.
2. Remove the hardware securing the Custom-Cut Baffle to the cutter deck.

- NOTE -

Hardware location used in the illustrations are for reference only. Location of hardware may vary depending on cutter deck size.

6.7 CUSTOM-CUT BAFFLE ADJUSTMENT

The Custom-Cut Baffle is designed to deliver optimum airflow and superior cutting performance in any type of grass. The Custom-Cut Baffle can be raised or lowered to precisely tailor the deck's performance for the type of grass being cut. The baffle can be set in seven (7) different positions for optimum performance.

A. 3-1/2" or 3-3/4" Position - (See Figure 6-9). For very tall, wiry or tough-to-cut grass.

3. Move the Custom-Cut Baffle to desired position. See Figure 6-9.
4. Reinstall the mounting hardware. Torque hardware to 39 ft-lbs.

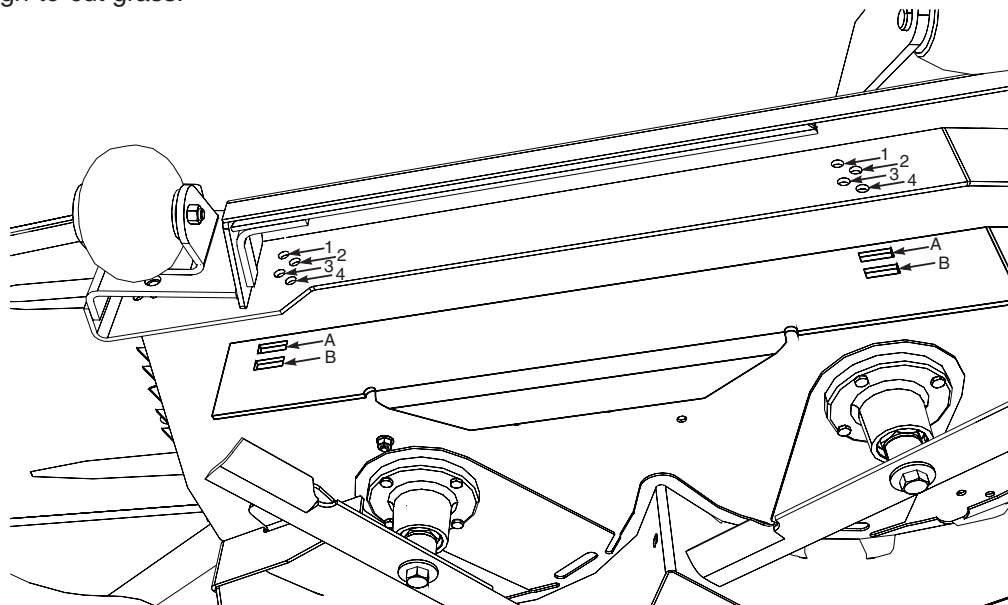

Custom-Cut Baffle Adjustment

Mounting Slot Selected	Mounting Hardware Location			
	Hole 1	Hole 2	Hole 3	Hole 4
Slot "A" Height (inches)	3-3/4"	4-1/4"	4-3/4"	5-1/4"
Slot "B" Height (inches)		Hole 2 3-1/2"	Hole 3 4"	Hole 4 4-1/2"

Figure 6-9. 7-Position Custom-Cut Baffle Adjustment

Section 6

6.8 ELECTRIC CLUTCH ADJUSTMENT

The electric clutch serves two functions in the operation of the mower. In addition to starting and stopping the power flow to the cutter blades, the clutch also acts as a brake to assist in stopping blade rotation when the PTO is switched off or the operator presence circuit is interrupted.

When the clutch is disengaged, the air gap between the armature and rotor must be adjusted to fifteen thousandths of an inch, 0.015, for proper operation. The airgap adjustment is made at three bolts on the clutch. There are three inspection windows, one next to each adjusting bolt. See Figure 6-10.

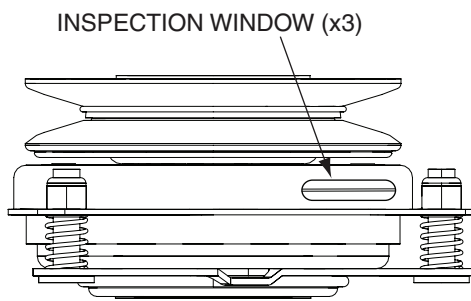

Figure 6-10. Clutch Air Gap Adjustment

1. Locate the inspection windows on the clutch.
2. Place a 0.015 feeler gauge in the slot between the rotor and the armature. See Figure 6-11.

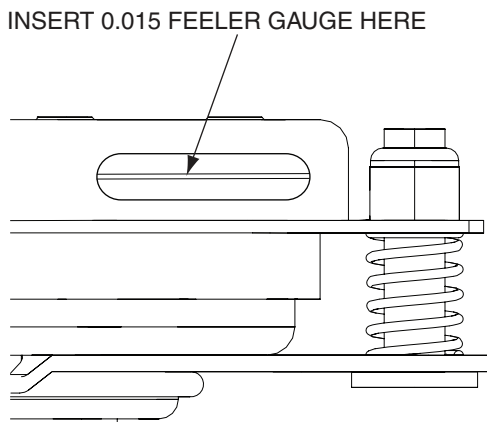

Figure 6-11. Clutch Air Gap Adjustment

3. Tighten or loosen the adjusting bolt as needed to achieve the 0.015 inch airgap. See Figure 6-12. Perform this operation at all three inspection windows.

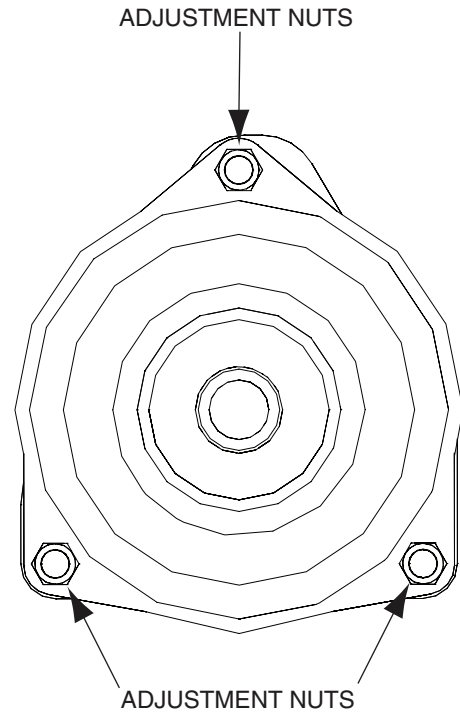

Figure 6-12. Clutch Air Gap Adjustment

This adjustment should be done every 500 hours of operation or annually, whichever comes first. In cases where the machine is heavily used, airgap settings should be checked more often.

If the air gap is too narrow, the clutch armature may drag when disengaged, resulting in premature failure.

MAINTENANCE

7.1 MAINTENANCE CHART - RECOMMENDED SERVICE INTERVALS

BREAK-IN (FIRST 10)	HOURS						PROCEDURE	COMMENTS
	8	20	40	100	200	500		
X							Check all hardware for tightness	
X							Check hydraulic oil level	See paragraph 7.3
X							Check all belts for proper alignment	See paragraph 7.8
	X						Check hydraulic fittings and hoses for leaks	Use extreme caution when checking the hydraulic hoses. See paragraph 2.6
	X						Check engine oil level	See paragraph 7.4
	X						*Clean mower	See paragraph 7.13
	X						Check condition of blades	See paragraph 7.9
	X						Apply grease to fittings	See paragraph 7.2
	X						Check tire pressure	See paragraph 7.10
	X						Inspect seat belt for wear or damage	See paragraph 2.5
	X						Check the operator interlock system	See paragraph 4.2
		X					Change engine oil and filter	See paragraph 7.4
			X				Check battery electrolyte level clean battery posts and cables	See paragraph 7.7
			X				Check belts for proper alignment	See paragraph 7.8
			X				Check condition of fuel lines	
				X			Apply grease to fittings	See paragraph 7.2
				X			Change engine oil	See paragraph 7.4
				X			*Clean air cleaner element	See paragraph 7.6

* Perform these maintenance procedures more frequently under extreme dusty or dirty conditions

Section 7

MAINTENANCE CHART - RECOMMENDED SERVICE INTERVALS (CONT'D)

BREAK-IN (FIRST 10)	HOURS					PROCEDURE	COMMENTS
	8	40	100	200	500		
				X		Apply grease to fittings	See paragraph 7.2
				X		Check hardware for tightness	
				X		Change engine oil filter	See paragraph 7.4
				X		Check hydraulic oil level	See paragraph 7.3
					X	Replace engine fuel filter	See paragraph 7.5
					X	Drain hydraulic system and replace hydraulic oil	Use SAE 20W50 Motor Oil. See paragraph 7.3
					X	Replace hydraulic oil filter	See paragraph 7.3
					X	Adjust electric PTO clutch	See Scag Dealer

7.2 LUBRICATION

GREASE FITTING LUBRICATION CHART (SEE FIGURE 7-1)

LOCATION	LUBRICATION INTERVAL	LUBRICANT	NO. OF PLACES
1 Caster Wheel Pivot *	500 Hours/Yearly	Chassis Grease	2
2 Caster Wheel Bearings	100 Hours/Monthly	Chassis Grease	2
3 Brake Actuator	200 Hours/Monthly	Chassis Grease	2
4 Cutter Deck Bellcranks	100 Hours/Bi-Weekly	Chassis Grease	4
5 Cutter Deck Pusharms	100 Hours/Bi-Weekly	Chassis Grease	2
6 Control Pivot	100 Hours/Bi-Weekly	Chassis Grease	2
6 Cutter Deck Spindle	40 Hours/Weekly	+Lithium MP White Grease 2125	3
7 Brake Handle	200 Hours/Monthly	Chassis Grease	1

+ Compatible Greases:

- Mobilix #2 found at Mobil Service Stations
- Ronex MP found at Exxon Service Stations
- Super Lube MEP #2 & Super Stay-M #2 found at Conoco Stations
- Shell Alvania #2 found at Shell Service Stations
- Lidok EP #2 found at industrial shops
- Timken Lithium Multi-Use #2 found at industrial shops

* **PROCEDURE:** Remove grease cap, part number 481559. Remove plug, part number 482028-01, and install grease zerk. Apply grease to the fitting until new grease appears at the top of the caster extension. Remove the grease zerk and reinstall the plug. Reinstall the grease cap. Special tool, part number 47007, is recommended for use in the installation of the grease cap.

GREASE FITTING LUBRICATION Lubricant Interval

□ Lithium MP White Grease 2125
(40 Hours/Weekly)

○ Chassis Grease
(100 Hours/Bi-monthly)

⬡ Chassis Grease
(200 Hours/Monthly)

△ Chassis Grease
(500 Hours/Yearly)

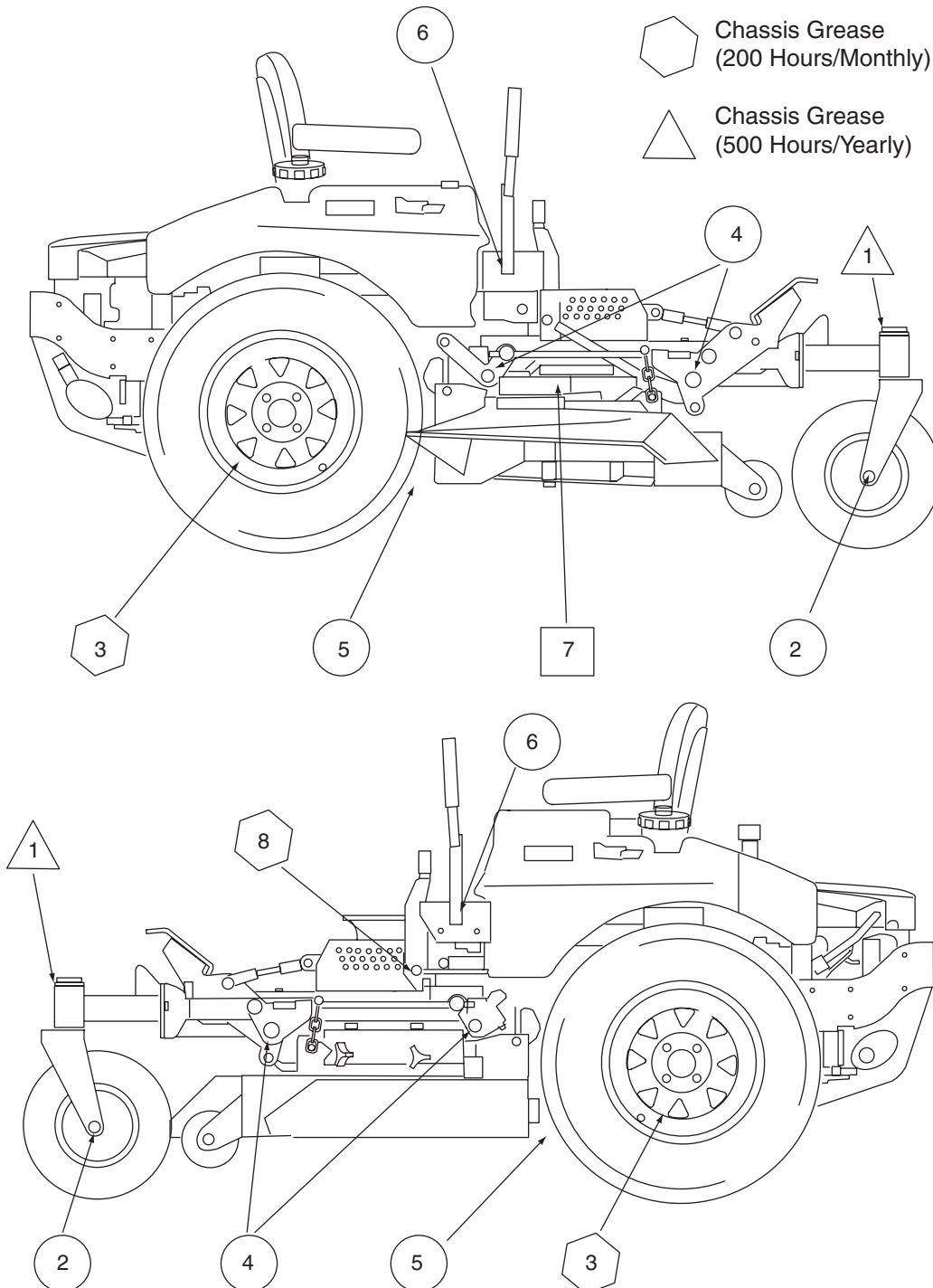

Figure 7-1. Lubrication Fitting Points

Section 7

7.3 HYDRAULIC SYSTEM

A. CHECKING HYDRAULIC OIL LEVEL

The hydraulic oil level should be checked after the first 10 hours of operation. Thereafter, check the oil after every 200 hours of machine operation or monthly, whichever occurs first.

- IMPORTANT -

If the oil level is consistently low, check for leaks and correct immediately.

1. Wipe dirt and contaminants from around the reservoir cap. Remove the cap from the hydraulic oil reservoir.
2. Visually check the level of hydraulic oil. Hydraulic oil must be at least 3" inches from top of the filler neck. If the level cannot be determined visually, use a clean tape measure to check the level. If the fluid is low, add 20W50 motor oil. DO NOT overfill; (overfilling the oil reservoir may cause oil seepage around the cap area).
3. Clean the fill cap and install it onto the reservoir.

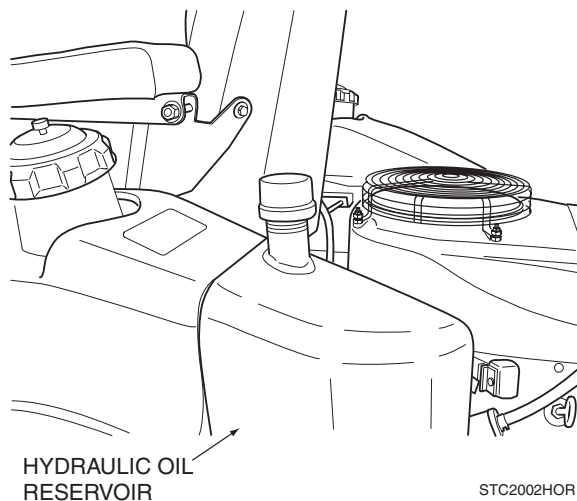

Figure 7-2. Hydraulic Oil Reservoir

B. CHANGING HYDRAULIC OIL

The hydraulic oil should be changed after every 500 hours or annually, whichever occurs first. The oil should also be changed if the color of the fluid has become black or milky. A black color and/or a rancid odor usually indicates possible overheating of the oil, and a milky color usually indicates water in the hydraulic oil.

- IMPORTANT -

The hydraulic oil should be changed if you notice the presence of water or a rancid odor to the hydraulic oil.

1. Park the mower on a level surface and stop the engine.
2. Place a suitable container under the hydraulic oil filter. Tilt the seat forward. Remove the fill cap from the reservoir and the drain plug from the bottom of the drain tee fitting on the front side of the filter base. See Figure 7-3. Allow the fluid to drain into the container and properly discard it.

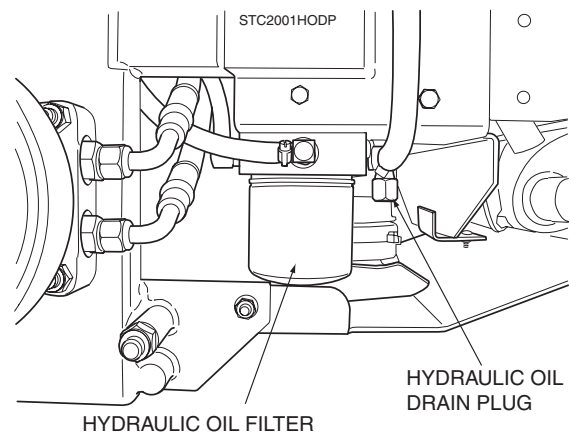

Figure 7-3. Hydraulic Oil Filter and Drain Plug

3. Re-install the drain plug into the tee fitting and be sure it is tight.

- NOTE -

Before refilling the hydraulic oil reservoir the hydraulic oil filter should be changed as outlined in Procedure C "Changing Hydraulic Oil Filter Element" on page 32.

4. Fill the reservoir to 3-1/4" inches from the top of the filler neck with 20W50 motor oil.
5. Replace the reservoir fill cap. Start the engine and drive forward and backward for two minutes. Check the oil level in the reservoir. If necessary, add oil to the reservoir.

C. CHANGING HYDRAULIC OIL FILTER ELEMENT

The hydraulic oil filter should be changed after every 500 hours of operation or annually, whichever occurs first.

1. Remove the oil filter element and properly discard it. See Figure 7-3. Fill the new filter with clean oil and install the filter. Hand tighten only.
2. Run the engine at idle speed with the speed control lever in neutral for five minutes.
3. Check the oil level in the hydraulic tank. It must be 3-1/4" inches from the top of the filler neck. If necessary, add SAE 20W50 motor oil.

7.4 ENGINE OIL

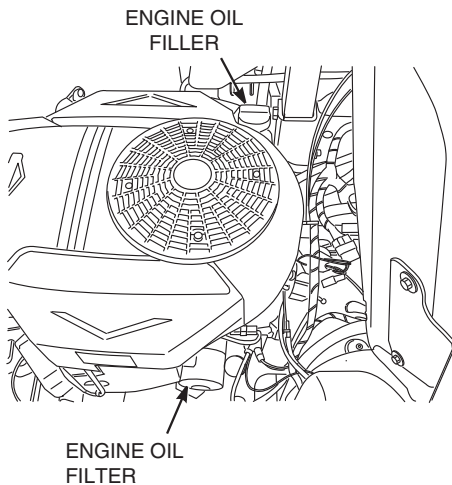

Figure 7-4. Briggs & Stratton Engine Oil Fill/Dipstick, and Filter Locations

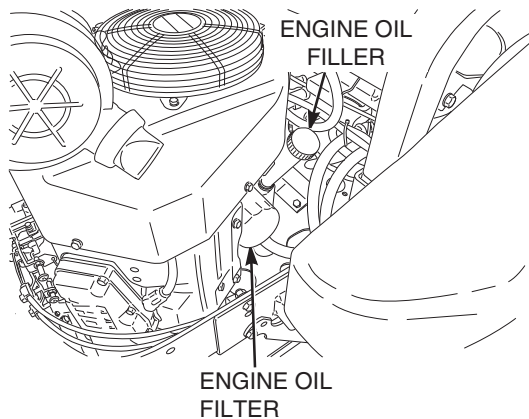

Figure 7-5. Kohler / Kawasaki Engine Oil Fill/Dipstick, and Filter Locations

A. CHECKING ENGINE CRANKCASE OIL LEVEL

The engine oil level should be checked after every 8 hours of operation or daily as instructed in the Engine Operator's Manual furnished with this mower.

B. CHANGING ENGINE CRANKCASE OIL

After the first 20 hours of operation, change the engine crankcase oil and replace the oil filter. Thereafter, change the engine crankcase oil after every 100 hours of operation or bi-weekly, whichever occurs first. Refer to the Engine Operator's Manual furnished with this mower for instructions.

C. CHANGING ENGINE OIL FILTER

After the first 20 hours of operation, replace the engine oil filter. Thereafter, replace the oil filter after every 200 hours of operation or every month, whichever occurs first. Refer to Engine Operator's Manual for instructions. See Figure 7-4 or Figure 7-5.

7.5 ENGINE FUEL SYSTEM

DANGER

To avoid injury from burns, allow the mower to cool before removing the fuel tank cap and refueling.

A. FILLING THE FUEL TANK

Fill the fuel tank at the beginning of each operating day. For EPA Phase 2 (produced prior to 1/1/2011) models, fill to within one (1) inch below the filler neck. For Low Emission (LE) and EPA Phase 3 (produced after 1/1/2011) models, fill to the bottom of the filler neck insert (approximately 4 gallons RH Fuel Tank and 3 Gallons LH Fuel Tank) at the beginning of each operating day. See Figure 7-6. Do not overfill. Use clean, fresh unleaded gasoline with a minimum octane rating of 87 and a maximum of 10% Ethanol.

DO NOT use E85 Fuel. Using E85 Fuel will cause severe damage to the engine.

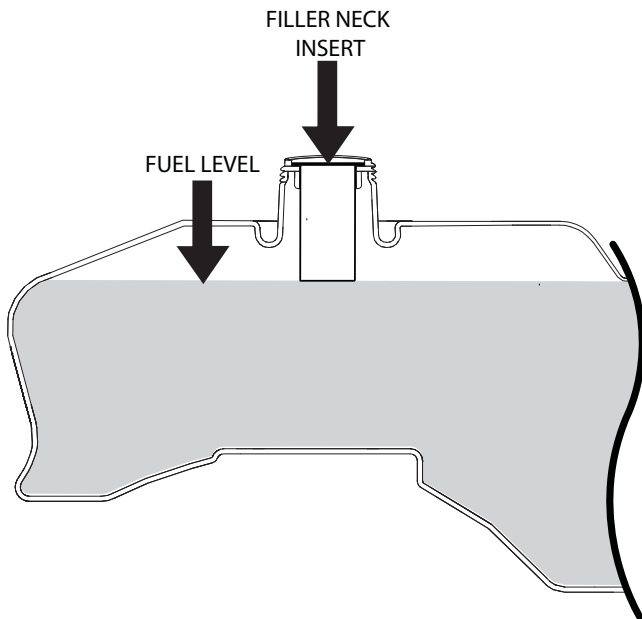

Figure 7-6. C.A.R.B. / EPA Phase 3 Fuel Level

To avoid personal injury or property damage, use extreme care in handling gasoline. Gasoline is extremely flammable and the vapors are explosive.

1. Extinguish all cigarettes, cigars, pipes and other sources of ignition.
2. Use only an approved gasoline container.
3. Never remove the gas cap or add fuel with the engine running. Allow the engine to completely cool before fueling.
4. Never fuel the machine indoors or in an enclosed trailer.
5. Never store the machine or fuel container where there is an open flame, spark or pilot light such as on a water heater or other appliances.
6. Never fill containers inside a vehicle or on a truck or trailer bed with a plastic liner. Always place containers on the ground away from your vehicle before filling.
7. Remove the machine from the truck or trailer and fuel on the ground. If this is not possible, then refuel the machine with a portable container, rather than from a gasoline dispenser nozzle.
8. Keep the nozzle in contact with the rim of fuel tank or container opening at all times until fueling is complete. Do not use a nozzle lock-open device.
9. If fuel is spilled on clothing, change clothing immediately and wash affected skin.

10. Replace gas cap and tighten securely. For Low Emission (LE) and EPA Phase 3 (produced after 1/1/2011) models, tighten the fuel cap until it ratchets.

B. REPLACING IN-LINE FUEL FILTER ELEMENTS

The engine fuel filter should be replaced after every 500 hours of operation or annually, whichever occurs first.

1. Close the shut-off valve.
2. Remove and replace the engine fuel filter. Open the fuel shut-off valve.

7.6 ENGINE AIR CLEANER

A. CLEANING AND/OR REPLACING AIR CLEANER ELEMENT

For any air cleaner, the operating environment dictates the air cleaner service periods. Inspect and clean the air cleaner element after every 100 hours of operation or bi-weekly, whichever occurs first and replace the element if required.

- NOTE -

In extremely dusty conditions it may be necessary to check the element once or twice daily to prevent engine damage.

1. Release the two latches securing the air cleaner cover to the air cleaner assembly and remove the cover. Set aside.
2. Remove the air cleaner and inspect.
3. Clean or replace the air cleaner and foam pre-cleaner as recommended by the engine manufacturer.
4. Replace the air cleaner cover and be sure to snap the two latches closed.

7.7 BATTERY

WARNING

Lead-acid batteries produce flammable and explosive gases. To avoid personal injury when checking, testing or charging batteries, **DO NOT** use smoking materials near batteries. Keep arcs, sparks and flames away from batteries. Provide proper ventilation and wear safety glasses.

WARNING

Battery posts, terminals, and related accessories contain lead and lead compounds, chemicals known to cause cancer and reproductive harm. Wash hands after handling.

WARNING

Electric storage battery fluid contains sulfuric acid which is **POISON** and can cause **SEVERE CHEMICAL BURNS**. Avoid contact of fluid with eyes, skin, or clothing. Use proper protective gear when handling batteries. **DO NOT** tip any battery beyond 45° angle in any direction. If fluid contact does occur, follow first aid suggestions below.

BATTERY ELECTROLYTE FIRST AID

External Contact — Flush with water.

Eyes — Flush with water for at least 15 minutes and get medical attention immediately.

Internal — Drink large quantities of water. Follow with Milk Of Magnesia, beaten egg, or vegetable oil. Get medical attention immediately. In case of internal contact, DO NOT give fluids that would induce vomiting.

A. CHARGING THE BATTERY

Refer to the battery charger's manual for specific instructions.

Under normal conditions the engine's alternator will have no problem keeping a charge on the battery. If the battery has been completely discharged for a long period of time, the alternator may not be able to recharge the battery, and a battery charger will be required.

DO NOT charge a frozen battery. It may explode and cause injury. Let the battery warm before attaching a charger.

Whenever possible, remove the battery from the mower before charging and make sure the electrolyte covers the plates in all cells.

WARNING

BATTERIES PRODUCE EXPLOSIVE GASES. Charge the battery in a well ventilated space so gases produced while charging can dissipate.

Charging rates between 3 and 50 amperes are satisfactory if excessive gassing or spewing of electrolyte does not occur or the battery does not feel excessively hot (over 125°F). If spewing or gassing occurs or the temperature exceeds 125°F, the charging rate must be reduced or temporarily stopped to permit cooling.

B. JUMP STARTING

1. The booster battery must be a 12 volt type. If a vehicle is used for jump starting, it must have a negative ground system.
2. When connecting the jumper cables, connect the positive cable to the positive battery post, then connect the negative cable to the negative battery post.

Section 7

7.8 DRIVE BELTS

All drive belts are spring-loaded and self-tensioning, however after the first 2, 4, 8 and 10 hours of operation, the belts should be checked for proper alignment and wear. Thereafter, check the belts after every 40 hours of operation or weekly, whichever occurs first.

- NOTE -

If you experience frequent belt wear or breakage, see your authorized Scag service center for belt adjustment.

7.9 CUTTER BLADES

A. BLADE INSPECTION

1. Remove the ignition key before servicing the blades.
2. Raise the mower deck to the highest position. Place the lanyard pin in the highest cutting height position to prevent the cutter deck from falling.

 <h2 style="margin: 0;">WARNING</h2>
<p>Always wear proper hand and eye protection when working with cutter blades.</p>

3. Check the cutter blades for straightness. If the cutter blades appear bent, they will need to be replaced.

 <h2 style="margin: 0;">WARNING</h2>
<p>Do not attempt to straighten a bent blade, and never weld a broken or cracked blade. Always replace it with a new blade to assure safety.</p>

4. If a blade cutting edge is dull or nicked, it should be sharpened. Remove the blades for sharpening. See "Blade Replacement."

- NOTE -

Keep the blades sharp. Cutting with dull blades not only yields a poor mowing job, but slows the cutting speed of the mower and causes extra wear on the engine and the blade drive by pulling hard.

B. BLADE SHARPENING

- NOTE -

If possible, use a file to sharpen the blade. Using a wheel grinder may burn the blade.

- NOTE -

DO NOT sharpen the blades beyond 1/3 of the width of the blade. See Figure 7-7.

1. Sharpen the cutting edge at the same bevel as the original. See Figure 7-7. Sharpen only the top of the cutting edge to maintain sharpness.

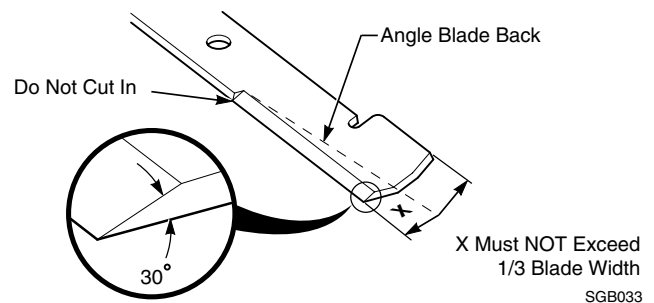

Figure 7-7. Blade Sharpening

2. Check the balance of the blade. If the blades are out of balance, vibration and premature wear can occur. See your authorized Scag dealer for blade balancing or special tools, if you choose to balance your own blades.

C. BLADE REPLACEMENT

 <h2 style="margin: 0;">WARNING</h2>
<p>Always wear proper hand and eye protection when working with cutter blades.</p>

1. Remove the ignition key before replacing the blades.
2. Raise the mower deck to the highest position. Place the lanyard pin in the highest cutting height position to prevent the cutter deck from falling.

- Secure the cutter blades to prevent them from rotating, (use the optional Blade Buddy tool P/N 9212, to assist in securing the cutter blades), remove the nut from the blade attaching bolt. Remove the cutter blade, bolt and spacer from the spindle shaft. See Figure 7-8.

- NOTE -

The front of the machine will have to be raised slightly to remove the blade bolt from the cutter spindle.

- To install the new cutter blade, put the flat washer onto the blade bolt and slide the bolt into the hole in the cutter blade.

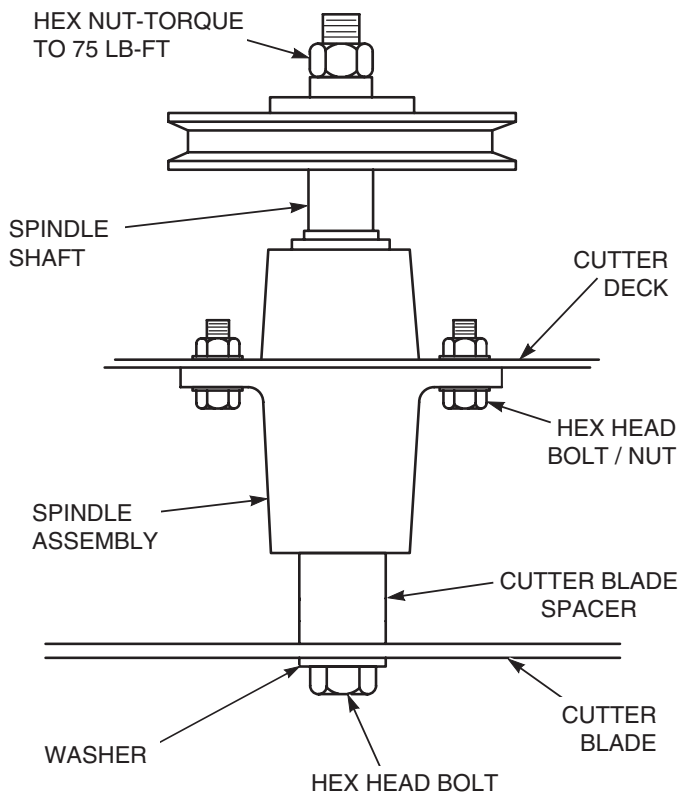

Figure 7-8. Blade Replacement

- NOTE -

Be sure that the blade is installed with the lift wing toward the top.

- Install the spacer onto the blade bolt and insert the bolt into the cutter spindle shaft.
- Install the hex nut to the blade bolt at the top of the cutter spindle. Secure the blades from rotating and torque to 75 ft/lbs. See Figure 7-8.

7.10 TIRES

Check the tire pressures after every 8 hours of operation or daily.

Caster Wheels	25 PSI
Drive Wheels	12 PSI

7.11 BODY, DECK, AND UPHOLSTERY

CAUTION

Do not wash any portion of the equipment while it is hot. Do not wash the engine; use compressed air.

- After each use, wash the mower and cutter deck. Use cold water and automotive cleaners. Do not use pressure cleaners.
- Do not spray electrical components.
- Use a mild soap solution or a vinyl/rubber cleaner to clean the seat.
- Repair damaged metal surfaces using Scag touch-up paint available from your authorized Scag dealer. Wax the mower for maximum paint protection.

ILLUSTRATED PARTS LIST

8.1 SCAG APPROVED ATTACHMENTS AND ACCESSORIES.

Attachments and accessories manufactured by companies other than Scag Power Equipment are not approved for use on this machine.

Scag approved attachments and accessories:

- GC-STC-V, GC-STWC-61V (p/n 9057, p/n 9058)
- GC-STC-CSV, GC-STWC-CS61V (p/n 9061, p/n 9062)
- Mulch Plate (p/n 9286, 9287, 9288)
- Hurricane Mulch (p/n 9283, 9284, 9285)
- STC Hitch (p/n 9241)
- STC - Lights (p/n 9274)
- Tiger Striper (p/n 9269)
- GC-4D (p/n 9054)
- GC-F4 (p/n 9055)
- Soft Ride Seat (p/n 9291)
- Suspension Seat (p/n/ 9292)
- Blade Buddy (p/n 9212)
- Fixed ROPS Accessory (p/n 9506)
- Quick-Fit Controls (p/n 9289)
- Flat Free Tire (p/n 9277)
- 12" Chrome Wheel Covers (set of 2) (p/n 920J)

48V & 52V CUTTER DECKS

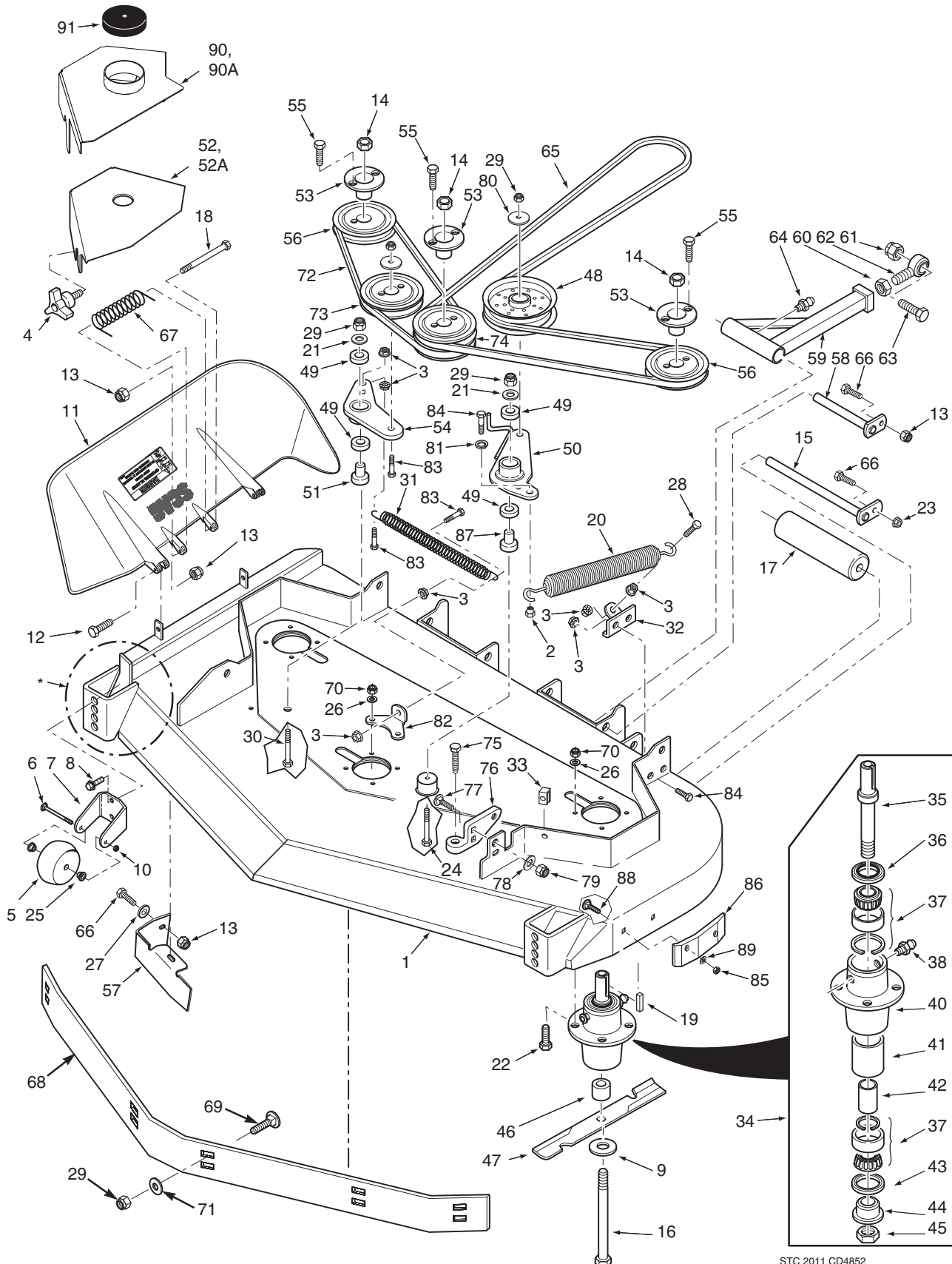

STC 2011 CD4852

* 52" cutter deck has a notch for anti-scalp roller

48V & 52V CUTTER DECKS

Ref. No.	Part No.	Description	48	52	Ref. No.	Part No.	Description	48	52
1	461854	Cutter Deck Velocity Plus	X		51	43689	Idler Pivot	X	X
	462363	Cutter Deck Velocity Plus (LE model)	X		52	424322	Belt Cover (48V)	X	
	461858	Cutter Deck Velocity Plus		X		424323	Belt Cover (52V)		X
2	43686	Boss, Spring Anchor	X	X	53	48926	Hub, Tapered 1-1/8" Bore	X	X
3	04019-04	Nut, 3/8-16 Serrated Flange	X	X	54	461946	Idler Arm	X	X
4	481625-01	Wing Nut, 3/8-16	X	X	55	04001-172	Bolt, Hex Head 1/4-20 x 1" Grade 8	X	X
5	481632	Anti-Scalp Wheel	X	X	56	483282	Pulley 4.75"	X	
6	04003-26	Bolt, Carriage 3/8-16 x 4"	X	X		483284	Pulley 5.35"		X
7	422478	Bracket, Anti-Scalp Wheel	X	X	57	424208	Turbo Baffle, Bolt On	X	X
8	04017-27	Bolt, Serrated Flange 3/8-16 x 1"	X	X		425619	Turbo Baffle, Bolt On (LE model only)	X	
9	04043-06	Flatwasher, 5/8" Hardened	X	X	58	451240	Push Arm Shaft	X	X
10	04021-05	Locknut, 3/8-16 Center Lock	X	X	59	461516	Push Arm (Includes 64,60,62)	X	X
11	461844	Discharge Chute	X		60	04020-16	Nut, 5/8-18 UNF	X	X
	461845	Discharge Chute		X	61	04021-13	Nut, Elastic Stop 5/8-11	X	X
12	04001-11	Bolt, Hex Head 5/16-18 x 1-1/2", Rear	X	X	62	48763	Rod End, 5/8 Male RH Thread	X	X
	04001-12	Bolt, Hex Head 5/16-18 x 1-3/4", Front	X	X	63	04001-79	Bolt, Hex Head 5/8-11 x 4-1/2"	X	X
13	04021-10	Nut, Elastic Stop 5/16-18	X	X	64	48114-04	Grease Fitting, 90 Degree	X	X
14	04020-09	Nut, 5/8-11 UNC	X	X	65	483241	Belt, Cutter Deck Drive (48V)	X	
15	45944	Shaft, Roller	X	X		483242	Belt, Cutter Deck Drive (52V)		X
16	04001-41	Bolt, Hex Head 5/8-11 x 9-1/2"	X	X	66	04001-09	Bolt, Hex Head 5/16-18 x 1"	X	X
17	48038	Roller, Rear	X	X	67	483378	Spring, Discharge Chute	X	X
18	04001-154	Bolt, Hex Head 5/16-18 x 4-3/4"	X	X	68	424839	Baffle Custom-Cut, 48V (7-Position)	X	
19	04063-08	Key, 1/4 x 1/4 x 2"	X	X		424840	Baffle Custom-Cut, 52V (7-Position)		X
20	483246	Spring, Idler LH	X	X	69	04003-23	Bolt, Carriage 3/8-16 x 1"	X	X
21	04043-04	Flatwasher, 3/8"	X	X	70	04021-22	Nut, Elastic Stop 5/16-18 Grade 8	X	X
22	04001-176	Bolt, Hex Head 5/16-18 x 1-3/4" Gr. 8	X	X	71	04043-04	Flatwasher 3/8"	X	X
23	04019-03	Nut, Serrated Flange 5/16-18	X	X	72	483239	Belt, RH Cutter Deck	X	X
24	04001-51	Bolt, Hex Head 3/8-16 x 3-3/4"	X	X		483240	Belt, RH Cutter Deck		
25	48100-15	Bushing, .376 ID Oilite	X	X	73	48181	Pulley, Idler 5" Dia.	X	X
26	04030-03	Lockwasher 5/16"	X	X	74	483283	Pulley, Double Groove	X	X
27	04040-15	Flatwasher 5/16"	X	X		483285	Pulley, Double Groove		
28	04001-136	Bolt, Hex Head 3/8-16 x 1-1/2" Gr. 8	X	X	75	483167	Bolt, Special	X	X
29	04021-09	Nut, Elastic Stop 3/8-16	X	X	76	461929	Lever Assy., Deck Level	X	X
30	04001-31	Bolt, Hex Head 3/8-16 x 2-1/2"	X	X	77	04003-40	Bolt, Carriage 7/16-14 x 1-1/4"	X	X
31	483247	Spring, Idler RH	X	X	78	04040-11	Flatwasher, 7/16-.500 x 1.25 x .083"	X	X
32	424369	Bracket, Spring Anchor LH 48V	X		79	04021-11	Nut, Elastic Stop 7/16-14	X	X
	424409	Bracket, Spring Anchor LH 52V		X	80	424367	Dust Shield	X	X
33	04110-03	U-Nut, 3/8-16	X	X	81	04030-03	Lockwasher 3/8"	X	X
34	461663	Spindle Assembly	X	X	82	424376	Bracket, Spring Anchor RH	X	X
35	43589	Shaft, Spindle	X	X		424377	Bracket, Spring Anchor RH		
36	481024	Seal Upper	X	X	83	04001-136	Bolt, Hex Head 3/8-16 x 1-1/2" Gr. 8	X	X
37	481022	Bearing Assembly	X	X	84	04001-19	Bolt, Hex Head 3/8-16 x 1"	X	X
38	48114-04	Grease Fitting	X	X	85	04021-04	Nut, Center Lock 5/16-18	X	X
39	48677	Valve, Grease Relief	X	X	86	483176	Wear Pad	X	X
40	43644	Housing, Spindle	X	X	87	43689	Idler Pivot	X	X
41	43312	Spacer, Outside	X	X	88	04003-12	Bolt, Carriage 5/16-18 x 3/4"	X	X
42	43296	Spacer, Inside	X	X	89	04040-04	Flatwasher, 5/16"	X	X
43	481025	Seal, Lower	X	X	90	462359	Belt Cover Weldm., RH-STC48V-LE (LE model only, incl. #91)	X	
44	43297	Bushing, Bottom	X	X	90A	462358	Belt Cover Weldm., LH-STC48V-LE (LE model only, incl. #91)	X	
45	481035	Nut, Special 1-1/16 - 18	X	X	91	484368	Cap, Spindle (LE model only)	X	
46	43590	Spacer, Spindle	X	X					
47	482877	Cutter Blade 16.5"	X						
	482878	Cutter Blade 18"		X					
48	483210	Pulley, Idler 5" Dia.	X	X					
49	48224	Bearing	X	X					
50	461940	Idler Arm Assy.	X	X					

61V CUTTER DECK

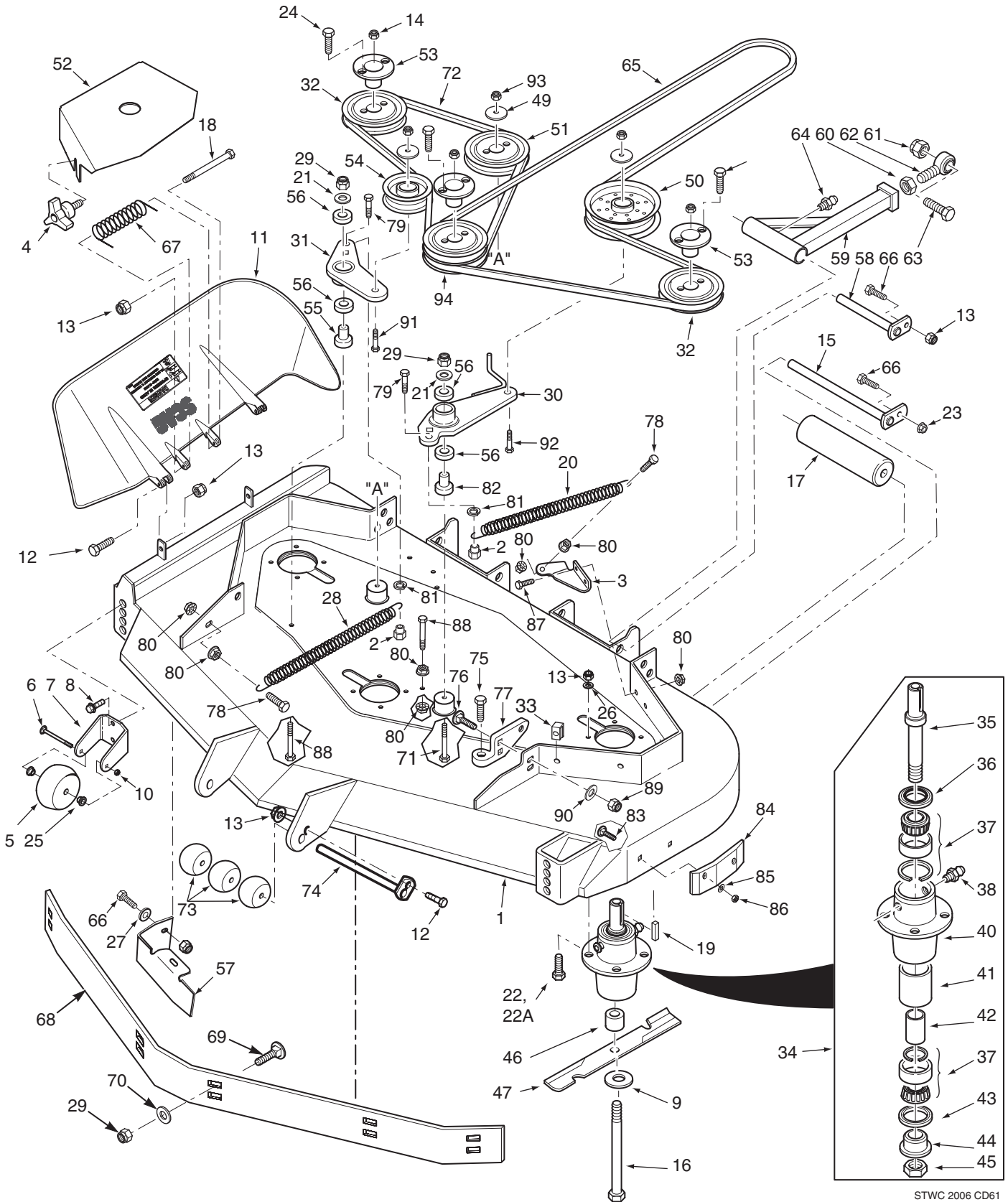

STWC 2006 CD61

61V CUTTER DECK

Ref. No.	Part No.	Description
1	461862	Cutter Deck Velocity Plus
2	43687	Boss, Spring Anchor
3	424371	Bracket, LH Spring Anchor 61V
4	481625-01	Wing Nut, 3/8-16
5	481632	Anti-Scalp Wheel
6	04003-26	Bolt, Carriage 3/8-16 x 4"
7	422478	Bracket, Anti-Scalp Wheel
8	04017-27	Bolt, Serrated Flange 3/8-16 x 1"
9	04043-06	Flatwasher, 5/8" Hardened
10	04021-05	Locknut, 3/8-16 Center Lock
11	461846	Discharge Chute
12	04001-11	Bolt, Hex Head 5/16-18 x 1-1/2", Rear
	04001-12	Bolt, Hex Head 5/16-18 x 1-3/4", Front
13	04021-10	Nut, Elastic Stop 5/16-18
14	04020-09	Nut, 5/8-11 UNC
15	45944	Shaft, Roller
16	04001-41	Bolt, Hex Head 5/8-11 x 9-1/2"
17	48038	Roller, Rear
18	04001-154	Bolt, Hex Head 5/16-18 x 4-3/4"
19	04063-08	Key, 1/4 x 1/4 x 2"
20	483246	Spring, LH Deck Drive
21	04043-04	Flatwasher, 3/8" - .938 x .391 x .105"
22	04001-176	Bolt, Hex Head 5/16-18 x 1-3/4" Grade 8
23	04019-03	Nut, Serrated Flange 5/16-18
24	04001-172	Bolt, Hex Head 1/4-20 x 1" Grade 8
25	48100-15	Bushing, .376 ID Oilite
26	04030-03	Lockwasher 5/16"
27	04040-15	Flatwasher 5/16"
28	483703	Spring, RH Deck Drive
29	04021-09	Nut, Elastic Stop 3/8-16
30	461940	Idler Arm Assembly, LH Drive
31	461946	Idler Arm Assembly, RH Drive
32	483286	Pulley, Tapered Bore 6.33" Dia.
33	04110-03	U-Nut, 3/8-16
34	461663	Spindle Assembly
35	43589	Shaft, Spindle
36	481024	Seal Upper
37	481022	Bearing Assembly
38	48114-04	Grease Fitting
39	48677	Valve, Grease Relief
40	43644	Housing, Spindle
41	43312	Spacer, Outside
42	43296	Spacer, Inside
43	481025	Seal, Lower
44	43297	Bushing, Bottom
45	481035	Nut, Special 1-1/16 - 18
46	43590	Spacer, Spindle
47	482879	Cutter Blade 21"
48	483287	Pulley, Double Groove 6.33" Dia.
49	424367	Dust Shield
50	483210	Idler Pulley, 5" Dia.

Ref. No.	Part No.	Description
51	48181	Idler Pulley, 5" Dia.
52	424575	Belt Cover (61V)
53	48926	Hub, Tapered 1-1/8" Bore
54	483415	Idler Pulley, 3-1/2" Dia.
55	43689	Pivot, Idler
56	48224	Bearing
57	424209	Turbo Baffle, Bolt On
58	451240	Push Arm Shaft
59	461516	Push Arm (Includes 64,60,62)
60	04020-16	Nut, 5/8-18 UNF
61	04021-13	Nut, Elastic Stop 5/8-11
62	48763	Rod End, 5/8 Male RH Thread
63	04001-79	Bolt, Hex Head 5/8-11 x 4-1/2"
64	48114-04	Grease Fitting, 90 Degree
65	483243	Belt, Deck Drive 61V
66	04001-09	Bolt, Hex Head 5/16-18 x 1"
67	483185	Spring, Discharge Chute
68	424841	Baffle Custom-Cut, 61V (7-Position)
69	04003-23	Bolt, Carriage 3/8-16 x 1"
70	04041-07	Flatwasher, 3/8-.391 x .938 x .105"
71	04001-77	Bolt, Hex Head 3/8-16 X 3-1/2"
72	483157	Belt, Deck Drive RH
73	482295	Wheel, Anti Scalp
74	45944	Roller Shaft
75	483167	Bolt, Special
76	04003-40	Bolt, Carriage 7/16-14 x 1-1/4"
77	461929	Lever Assy., Deck Level
78	04001-136	Bolt, Hex Head 3/8-16 x 1-1/2" Gr.8
79	04001-19	Bolt, Hex Head 3/8-16 x 1"
80	04019-04	Nut, Serrated Flange 3/8-16
81	04030-04	Lockwasher, 5/16"
82	43689	Pivot, Idler Short
83	04003-12	Bolt, Carr. 5/16-18 x 3/4"
84	483176	Wear Pad
85	04040-04	Flatwasher, 5/16-.344 x .688 x .065"
86	04021-04	Nut, Center Lock 5/16"
87	04001-19	Bolt, Hex Head 3/8-16 x 1"
88	04001-31	Bolt, Hex Head 3/8-16 x 2-1/2"
89	04021-11	Nut, Elastic Stop 7/16-14
90	04040-11	Flatwasher, 7/16-.500 x 1.250 x .083"
91	04001-46	Bolt, Hex Head 3/8-16 x 2-1/4"
92	04001-54	Bolt, Hex Head 3/8-16 x 3"
93	04021-09	Nut, Elastic Stop 3/8-16
94	483287	Pulley, Double Groove 6.33" Dia.

CUTTER DECK CONTROLS

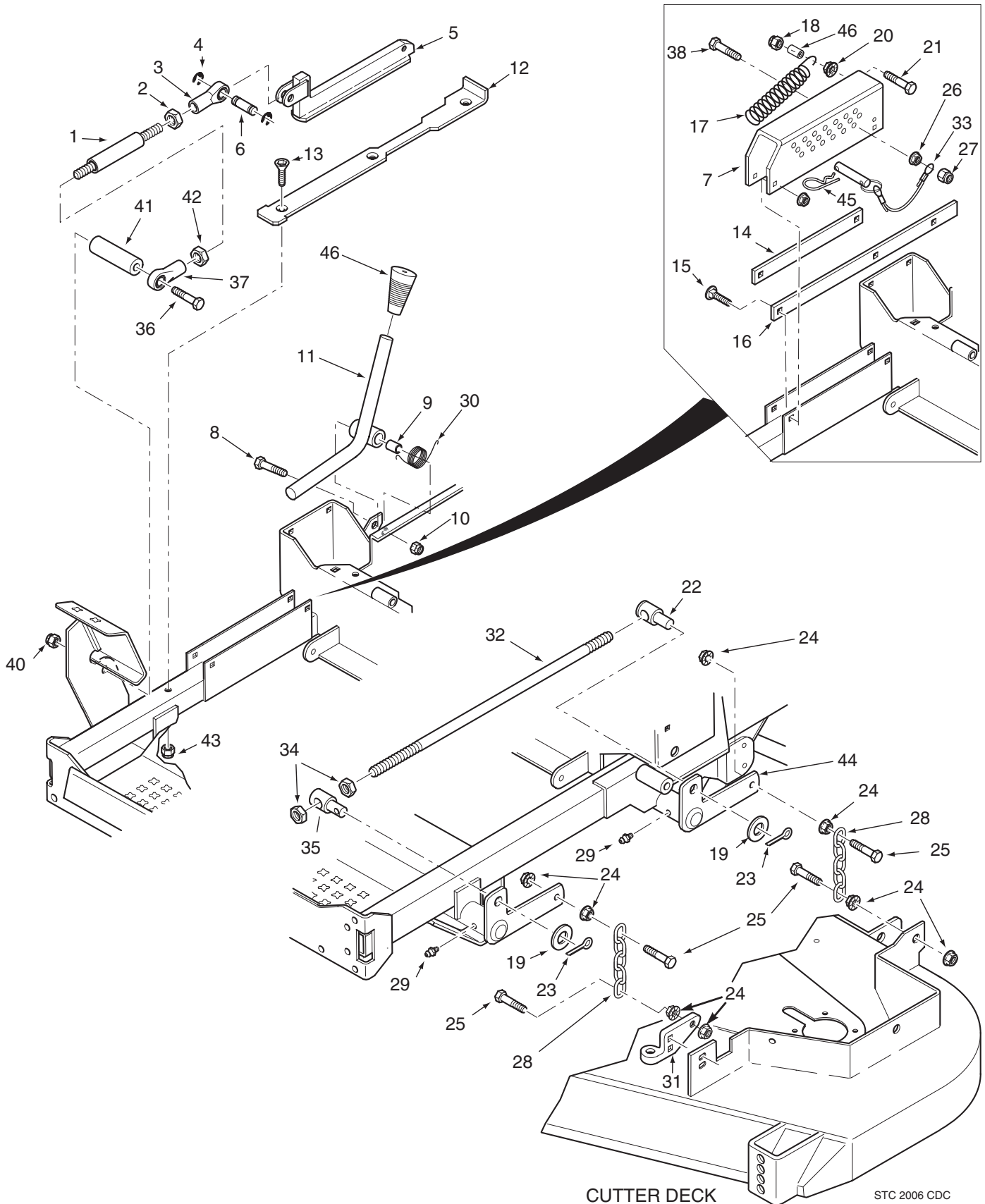

CUTTER DECK CONTROLS

Ref. No.	Part No.	Description
1	482624	Rod, Deck Lift Linkage
2	04020-28	Nut, Jam 1/2-20 LH Thread
3	481766	Rod End, 1/2-20 Female Thread
4	04050-10	Retaining Ring, 1/2" External "E"
5	483062	Slide, Deck Height Adjust
6	43487	Pin, Deck Lift
7	423463	Bracket, Cutting Height Adjustment
8	04001-22	Bolt, Hex Head 3/8-16 x 2-3/4"
9	43668	Bushing .502" OD
10	04021-09	Nut, Elastic Stop 3/8-16
11	461874	Lever, Deck Latch
12	422346	Slide, Cutting Height
13	04014-03	Screw, Cap 5/16-18 x 3" FHHS
14	422381	Guide, Short
15	04003-04	Bolt, Carriage 5/16-18 x 1"
16	422380	Guide, Long
17	483177	Spring, Helper
18	04021-05	Nut, 3/8-16 Center Lock
19	04040-09	Flatwasher, 5/8-.656 x 1.312 x .095"
20	04019-04	Nut, 3/8-16 Serr. Flange
21	04001-32	Bolt, Hex Head 3/8-16 x 1-1/4"
22	43678	Swivel Joint LH
23	04061-07	Cotter Pin, 3/16 x 1"
24	04019-04	Nut, Serr. Flange 3/8-16
25	04001-20	Bolt, Hex Head 3/8-16 x 1-1/2"
26	04019-04	Nut, Serr. Flange 3/8-16
27	04021-09	Nut, Elastic Stop 3/8-16
28	48540	Chain
29	48114-04	Grease Fitting, 1/4-28 Self Tap
30	483181	Torsion Spring
31	461929	Lever Assy., Deck Level
32	04004-45	Stud, 1/2-13 x 20"
33	04067-09	Pin
	481547	Lanyard
34	04020-09	Nut, 5/8-11 UNC
35	43679	Swivel Joint RH
36	04001-155	Bolt, Hex Head 1/2-13 x 5"
37	481765	Rod End, 1/2-20 Female RH Thread
38	04001-77	Bolt, Hex Head 3/8-16 x 3-1/2"
39	43572	Spacer
40	04021-02	Locknut, 1/4-20
41	43630	Spacer
42	04020-27	Nut, 1/2-20 UNF-2B
43	04021-10	Nut, Elastic Stop 5/16-18
44	45904	Lift Bellcrank Weldment, LH Rear
	45905	Lift Bellcrank Weldment, RH Rear
	04041-14	Flatwasher, 1.0-1.062 x 1.5 x .048"
	04050-08	Retaining Ring, 1" ext.
45	04062-04	Hair Pin Cotter, .177 x 3-1/4"
46	481477	Grip, Deck Latch Lever

SHEET METAL COMPONENTS

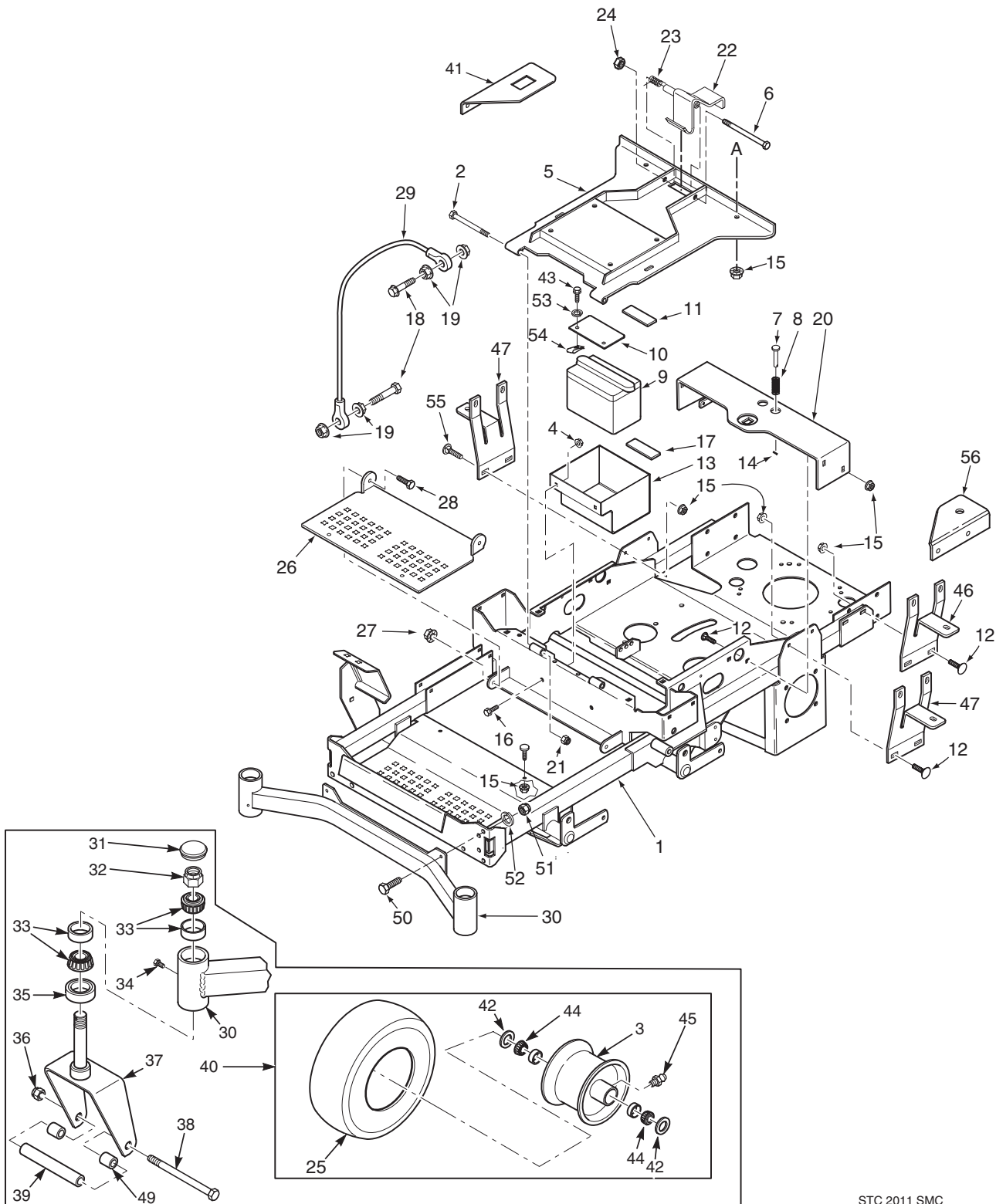

STC 2011 SMC

SHEET METAL COMPONENTS

Ref. No.	Part No.	Description
1	462325	Main Frame Assembly w/decals
2	04001-73	Bolt, Hex Head 5/16-18 x 3-3/4"
3	482625	Rim 48" & 52" (Includes Item 45)
	482620	Rim 61" (Includes Item 45)
4	04019-04	Nut, Serr. Flange 3/8-16
5	461989	Plate, Seat Mounting w/decals
6	04001-100	Bolt, Hex Head 3/8-16 x 6"
7	43462	Pin Retainer, Spring
8	481389	Spring
9	**	Battery (not available through Scag)
10	423571	Battery Cover
11	482553	Battery Hold Down Pad
12	04003-12	Bolt, Carr. 5/16-18 x 3/4"
13	423556	Battery Box
14	04060-01	Roll Pin, Spring 5/32 x 3/4"
15	04019-03	Nut, Serr. Flange 5/16-18
16	04001-19	Bolt, Hex Head 3/8-16 x 1"
17	482552	Pad, Rubber
18	04001-59	Bolt, Hex Head 1/4-20 x 1-1/4"
19	04019-02	Nut, Serr. Flange 1/4-20
20	451896	Seat Base Support
21	04021-10	Nut, Elastic Stop 5/16-18
22	451897	Seat Latch Weldment
23	483371	Spring, Seat Latch
24	04021-05	Locknut, 3/8-16 Center Lock
25	481613	Tire, 13 x 5.0-6 Smooth (48" & 52")
	482619	Tire, 13 x 6.5-6 Smooth (61")
26	423557	Footplate
27	04021-09	Nut, Elastic Stop 3/8-16
28	04001-19	Bolt, Hex Head 3/8-16 x 1"
29	48566	Cable, Seat Stop
30	452204	Weldment, Caster Support (48" & 52")
	452205	Weldment, Caster Support (61")

Ref. No.	Part No.	Description
31	484195	Cap, Grease
32	04021-20	Nut, Elastic Stop 1.0"-14
33	48668	Bearing Set
34	482028-01	Plug, 1/4-28
35	481025	Seal, 2.0" OD x 1.625" ID
36	04021-07	Nut, Elastic Stop 1/2-13
37	451471	Yoke, Front Caster Wheel
	451658	Yoke, Front Caster Wheel (61")
38	04001-134	Bolt, Hex Head 1/2-13 x 7-1/2"
	04001-167	Bolt, Hex Head 1/2-13 x 9-1/2" (61")
39	43581	Sleeve - 48" & 52"
	43583	Sleeve - 61"
40	482503	Caster Wheel Assembly
	482504	Caster Wheel Assembly (61")
41	424112	Bracket, Hour Meter
42	482622	Seal
43	04001-32	Bolt, Hex Head 3/8-16 x 1-1/4"
44	482621	Roller Bearing
45	48114-04	Fitting, Grease
46	423575	Mounting Bracket, Oil Tank
47	423764	Mounting Bracket, Fuel Tank
48	482633	Seat Pan
49	43584	Spacer, Caster Wheel
50	04001-28	Bolt, Hex Head 7/16-14 x 1-1/4"
51	04021-11	Nut, Elastic Stop 7/16-14
52	04030-05	Lockwasher, 7/16"
53	04030-04	Lockwasher, 3/8" Spring
54	04110-03	U-Nut, 3/8-16
55	04003-04	Bolt, Carriage 5/16-18 x 1"
56	423912	Bracket, Fuel Valve

STC FOLDABLE ROLL-OVER PROTECTION SYSTEM

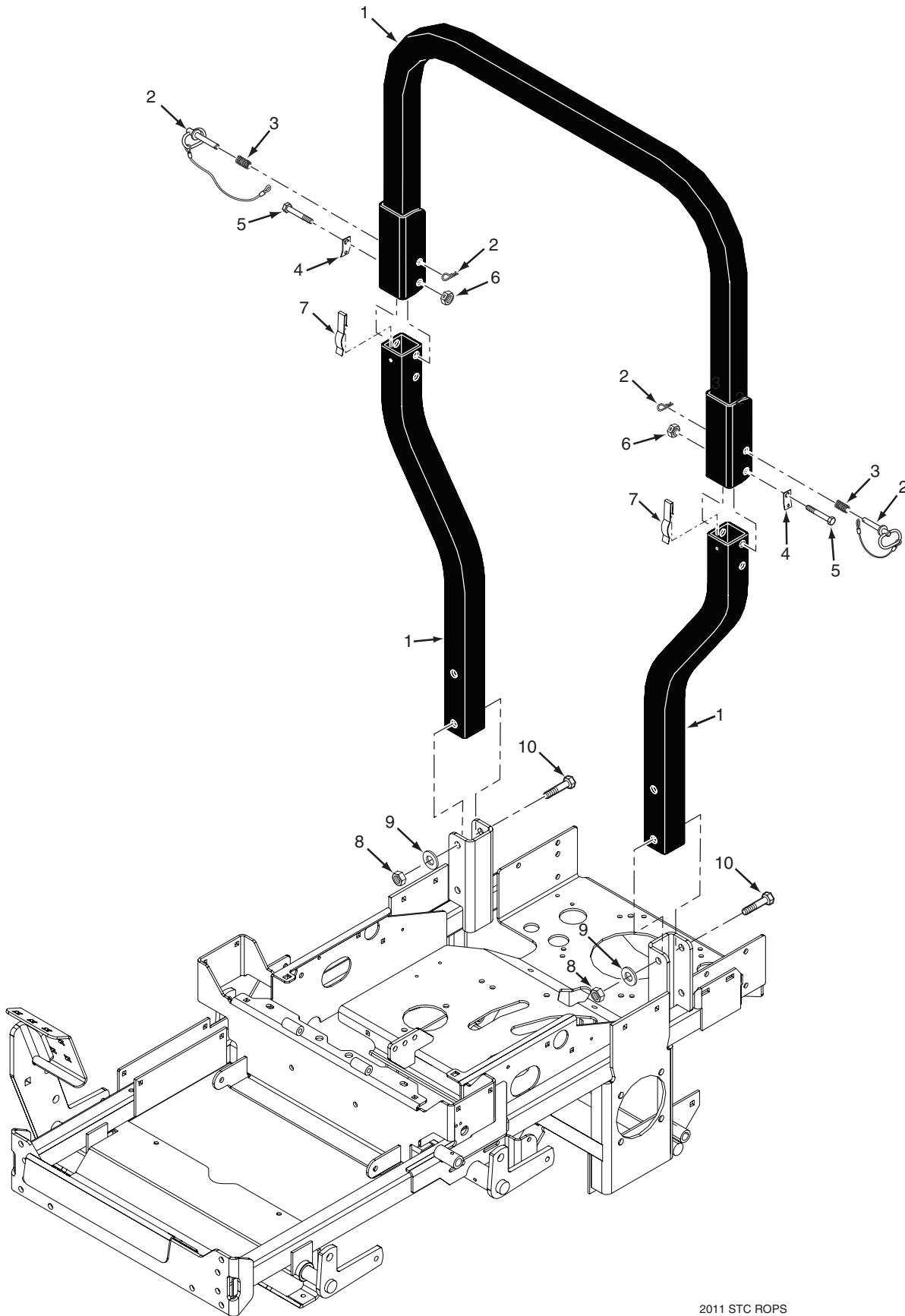

STC FOLDABLE ROLL-OVER PROTECTION SYSTEM

Ref. No.	Part No.	Description
1	462209	STC Foldable ROPS
2	484168	Pin Assembly (incl. #3 & #4)
3	484170	Spring, ROPS
4	484169	Clip, ROPS
5	04001-90	Bolt, Hex Head 1/2-13 x 3-1/4"
6	04021-19	Nut, Center Lock 1/2-13
7	484167	Spring Clip, ROPS
8	04021-19	Nut, Center Lock 1/2-13
9	04040-13	Flatwasher, 1/2-.562 x 1.375 x .109
10	04001-145	Bolt, Hex Head 1/2-13 x 3-1/2"

STC SUSPENSION SEAT

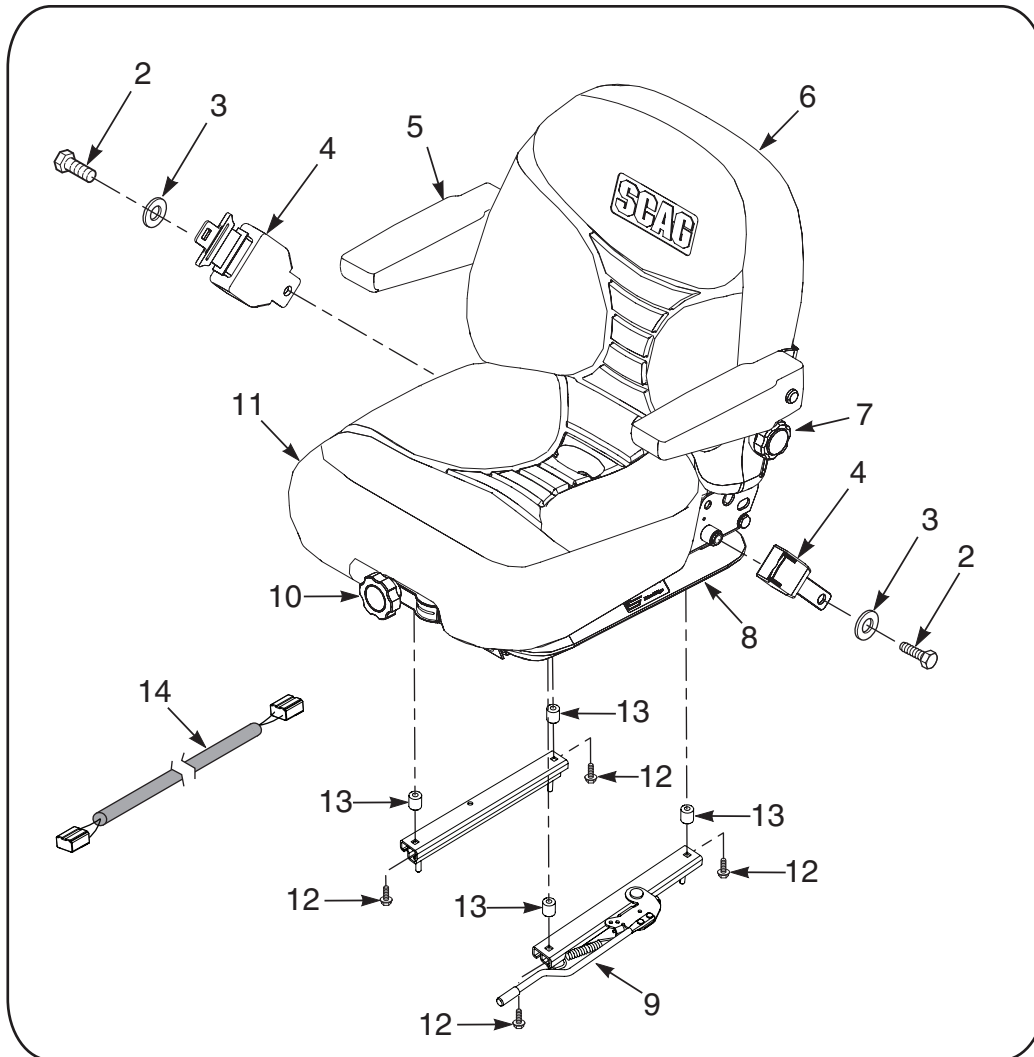

Ref. No.	Part No.	Description
1	9292	Suspension Seat Assembly w/seat belt
2	04001-178	Bolt, Hex Head 7/16-20 x 1"
3	04040-11	Flatwasher, 7/16-.500 x 1.25 x .083
4	483594	Retractable Seat Belt
5	482950	Armrest Only
	482945	Armrest Assembly Kit, LH
	482946	Armrest Assembly Kit, RH
6	482940	Back Cushion Kit
7	482943	Lumbar Kit
	482948	Knob Kit
8	482942	Shock Absorber Kit
9	482952	Seat Adjustment, Track Set
10	482944	Weight Adjustment Kit
	482948	Knob Kit
11	482941	Seat Cushion Kit
		Seat Drain Kit (Included with Seat Cushion)
12	04001-12	Bolt, Hex Head 5/16-18 x 1-3/4"
13	43572	Spacer
14	483440	Wire Harness Adapter

**STC SOFT RIDE SEAT USED ON
STC48V-26BS, STC48V-22FS & STC48V-22FS-LE MODELS ONLY**

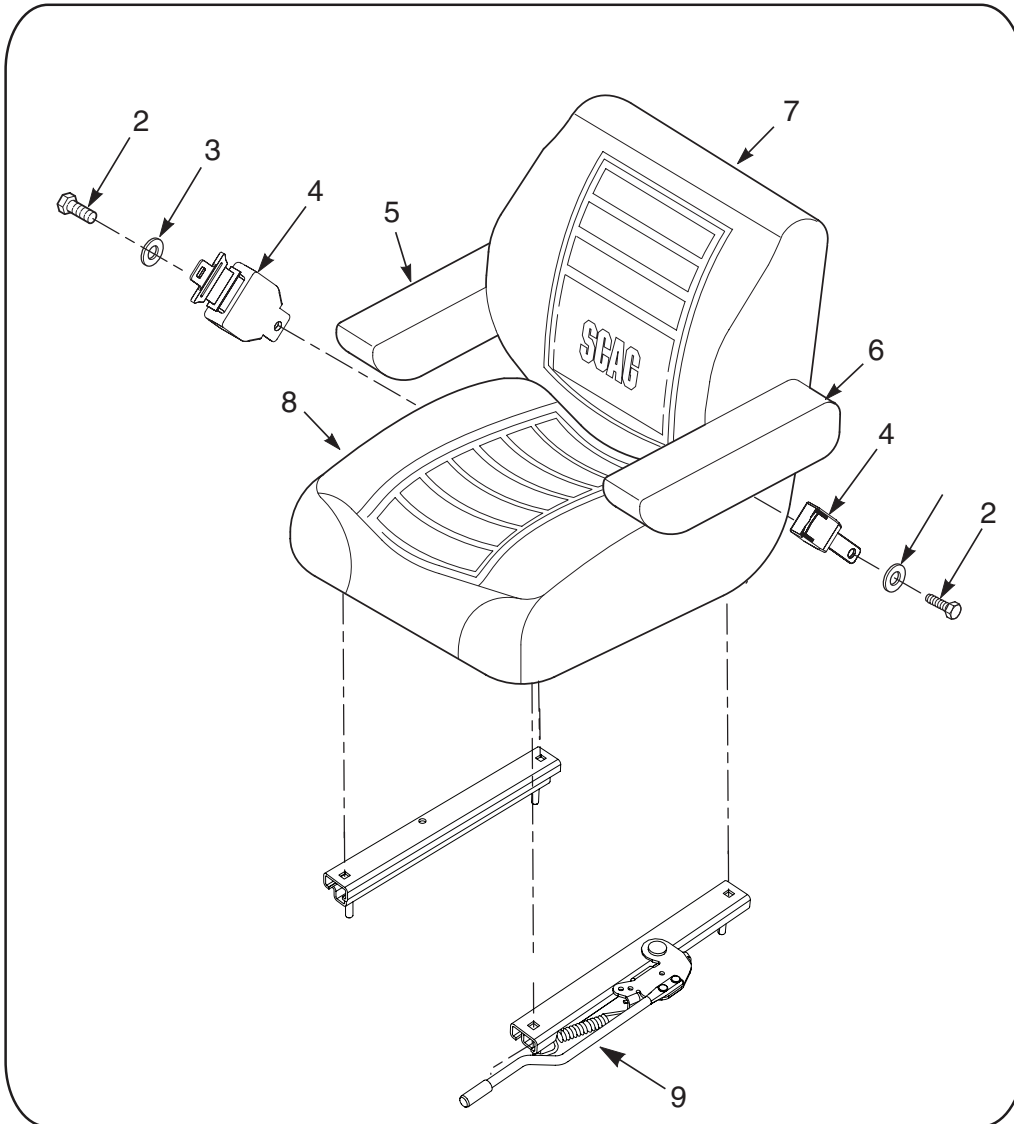

Ref. No.	Part No.	Description
1	483386	Seat Assembly
2	04001-178	Bolt, Hex Head 7/16-20 x 1"
3	04040-11	Flatwasher, 7/16-.500 x 1.25 x .083
4	483412	Retractable Seat Belt
5	482618	Armrest, RH
	482616	Cover, Armrest
6	482617	Armrest, LH
	482616	Cover, Armrest
7	482938	Cover, Backrest
8	482939	Cover, Cushion
9	482937	Seat Track Set

DRIVE SYSTEM COMPONENTS

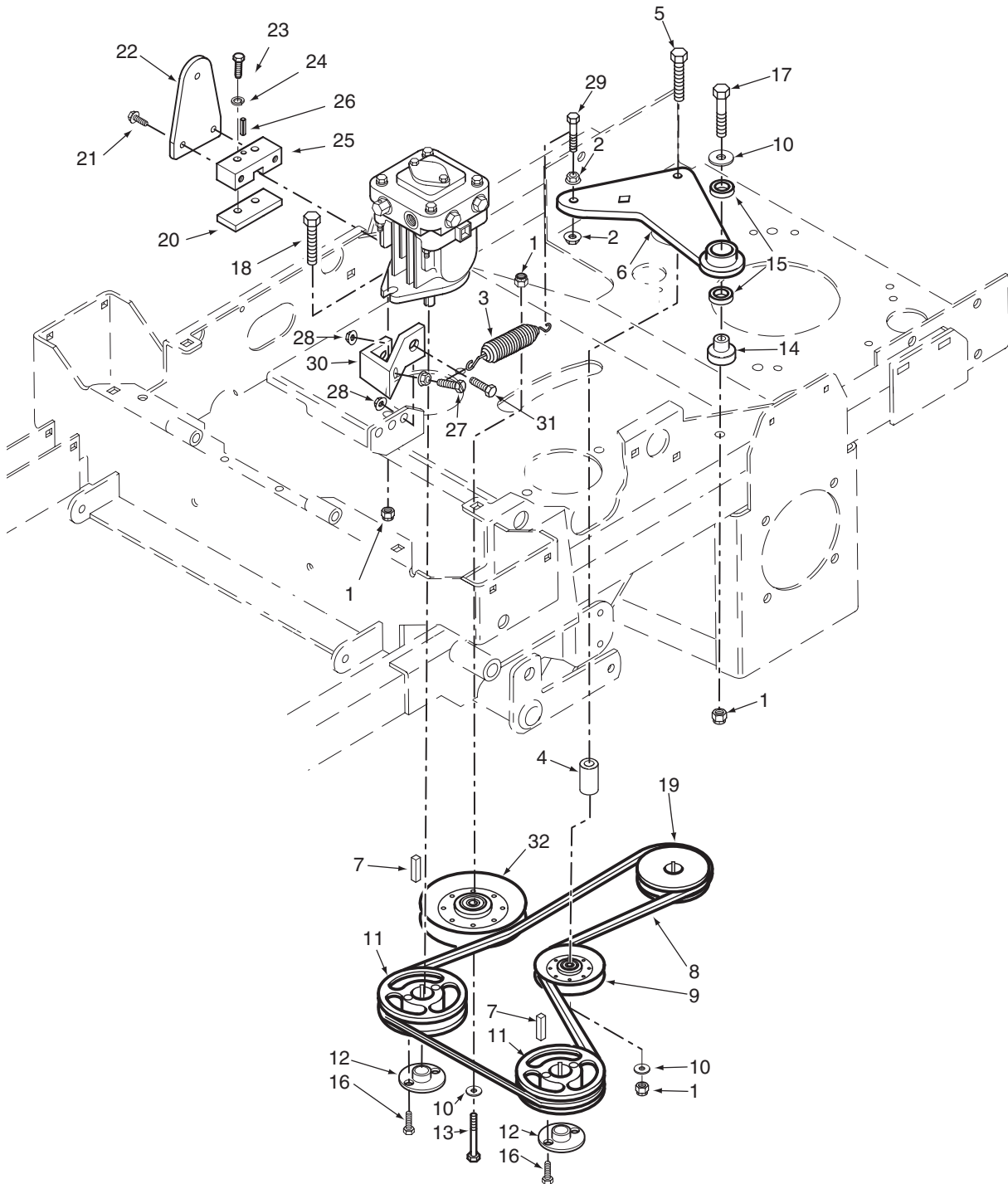

DRIVE SYSTEM COMPONENTS

Ref. No.	Part No.	Description
1	04021-09	Nut, Elastic Stop 3/8-16
2	04019-04	Nut, Serrated Flange 3/8-16
3	483087	Spring, Pump Idler
4	43286	Spacer
5	04001-22	Bolt, Hex Head 3/8-16 x 2-3/4"
6	461603	Idler Arm Assy., Pump Drive
7	04063-14	Key, 5 x 5 x 25mm
8	483172	Belt, Transmission
9	483415	Pulley, 3-1/2" Dia. Idler
10	04043-04	Flatwasher, 3/8-.391 x .938 x .105"
11	482744	Pulley, 5.75" OD Taper Bore
12	482085	Hub, Tapered, 15mm Bore
13	04001-45	Bolt, 3/8-16 x 2"
14	43503	Pivot, Idler
15	48224	Bearing
16	04001-172	Bolt, Hex Head 1/4-20 x 1" Grade 8
17	04001-31	Bolt, Hex Head 3/8-16 x 2-1/2"
18	04001-20	Bolt, Hex Head 3/8-16 x 1-1/2"
19	483081	Pulley, 5.75" Dia. - 1.125" Bore
20	421203	Clamp Plate
21	04017-05	Hex Head Capscrew, 1/4-20 x 3/4"
22	422969	Control Lever, Pump
23	04017-05	Hex Head Capscrew, 1/4-20 x 3/4"
24	04030-02	Lockwasher, 1/4"
25	48829	Block, Pump Control
26	04060-06	Roll Pin
27	04001-136	Bolt, Hex Head 3/8-16 x 1-1/2" Grade 8
28	04019-04	Nut, Serr. Flange 3/8-16
29	04001-136	Bolt, Hex Head 3/8-16 x 1-1/2" Grade 8
30	424137	Bracket
31	04001-19	Bolt, Hex Head 3/8-16 x 1"
32	483215	Pulley, 5" Dia. Idler

ENGINE & ATTACHING PARTS

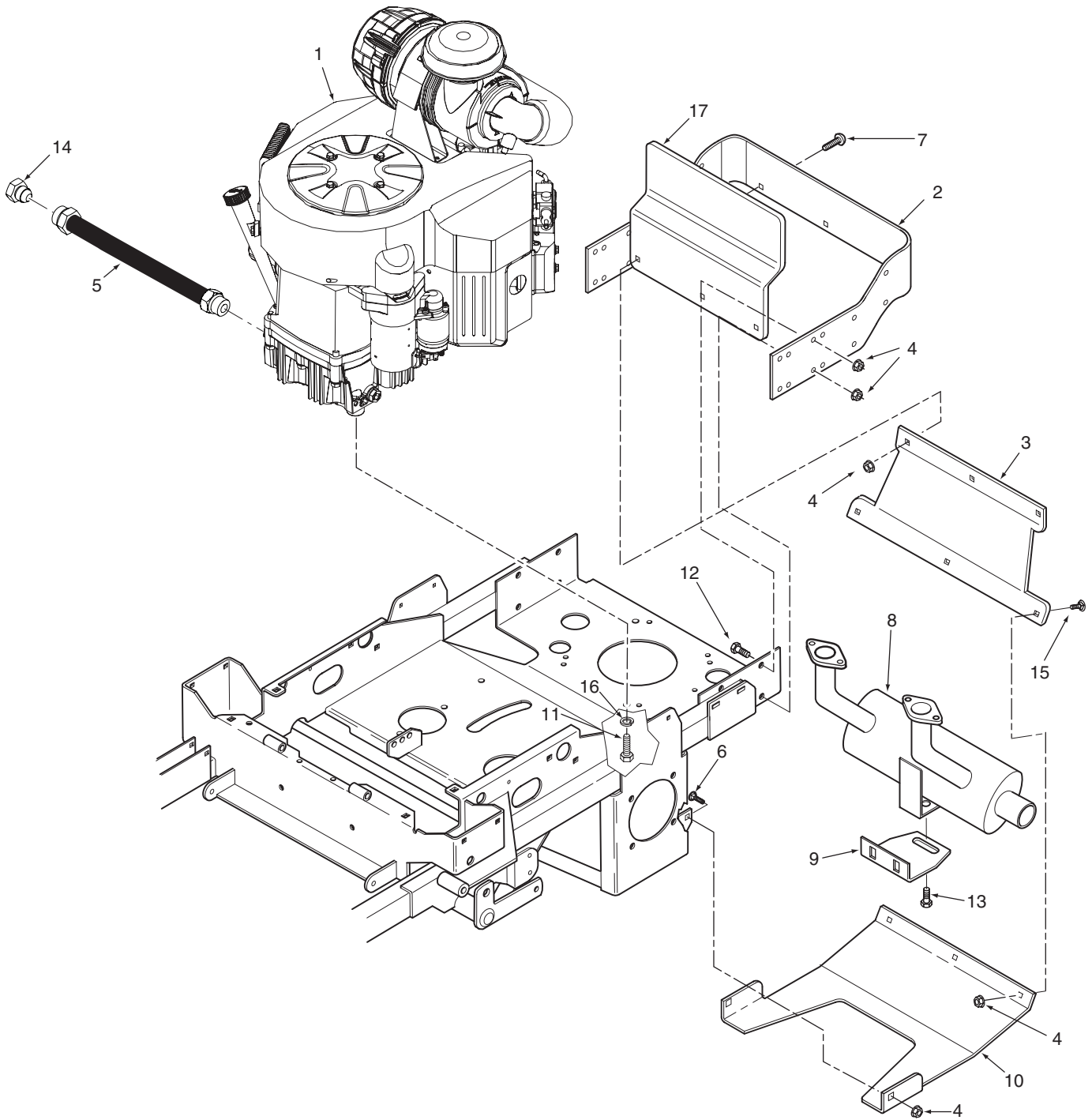

ENGINE & ATTACHING PARTS

Ref. No.	Part No.	Description
1	484298	Engine, Kawasaki FS651V, 22hp
	484228	Engine, Briggs & Stratton ELS, 26hp
	484225	Engine, Kawasaki FX691V, 24hp
	484226	Engine, Kohler Command, 25hp
	484227	Engine, Kohler Command, 27hp
2	423770	Bumper, Rear
3	424107	Shield, Rear (48" & 52")
	41031	Weight, Rear Shield (61" Only)
4	04019-04	Nut, Serr. Flange 3/8-16
5	484304	Hose, Oil Drain - Kawasaki FX / FS (incl. #14)
	484305	Hose, Oil Drain - Briggs & Stratton ELS (incl. #14)
	484306	Hose, Oil Drain - Kohler CV (Incl. #14)
6	04003-23	Bolt, Carr. 3/8-16 x 1"
7	04104-01	Bolt, 3/8-16 x 1" Torx
8	483288	Muffler (Briggs & Stratton)
	483266	Muffler (Kohler)
	484209	Muffler (Kawasaki)
9	424133	Bracket, Muffler
10	423555	Plate, Skid
11	04001-32	Bolt, Hex Head 3/8-16 x 1-1/4" (Kawasaki)
	04011-07	Bolt, Hex Head 3/8-16 x 1-1/4" Self Tap (Briggs and Kohler)
	04001-11	Bolt, Hex Head 5/16-18 x 1-1/2" (Right Front Engine Mounting, Briggs and Kohler Only)
	04019-03	Nut, Serrated Flange 5/16-18 (Right Front Engine Mounting, Briggs and Kohler Only)
12	04001-19	Bolt, Hex Head 3/8-16 x 1"
13	04011-12	Screw, Hex Head 5/16-18 x 3/4" Self Tap
14	483280-01	Tubing, Oil Drain 1/2" x 8"
15	04003-31	Bolt, Carr. 3/8-16 x 3/4"
16	04019-03	Nut, Serr. Flange 5/16-18
17	424415	Guard, Carb Inlet (STC48V-26BS Only)

STEERING COMPONENTS

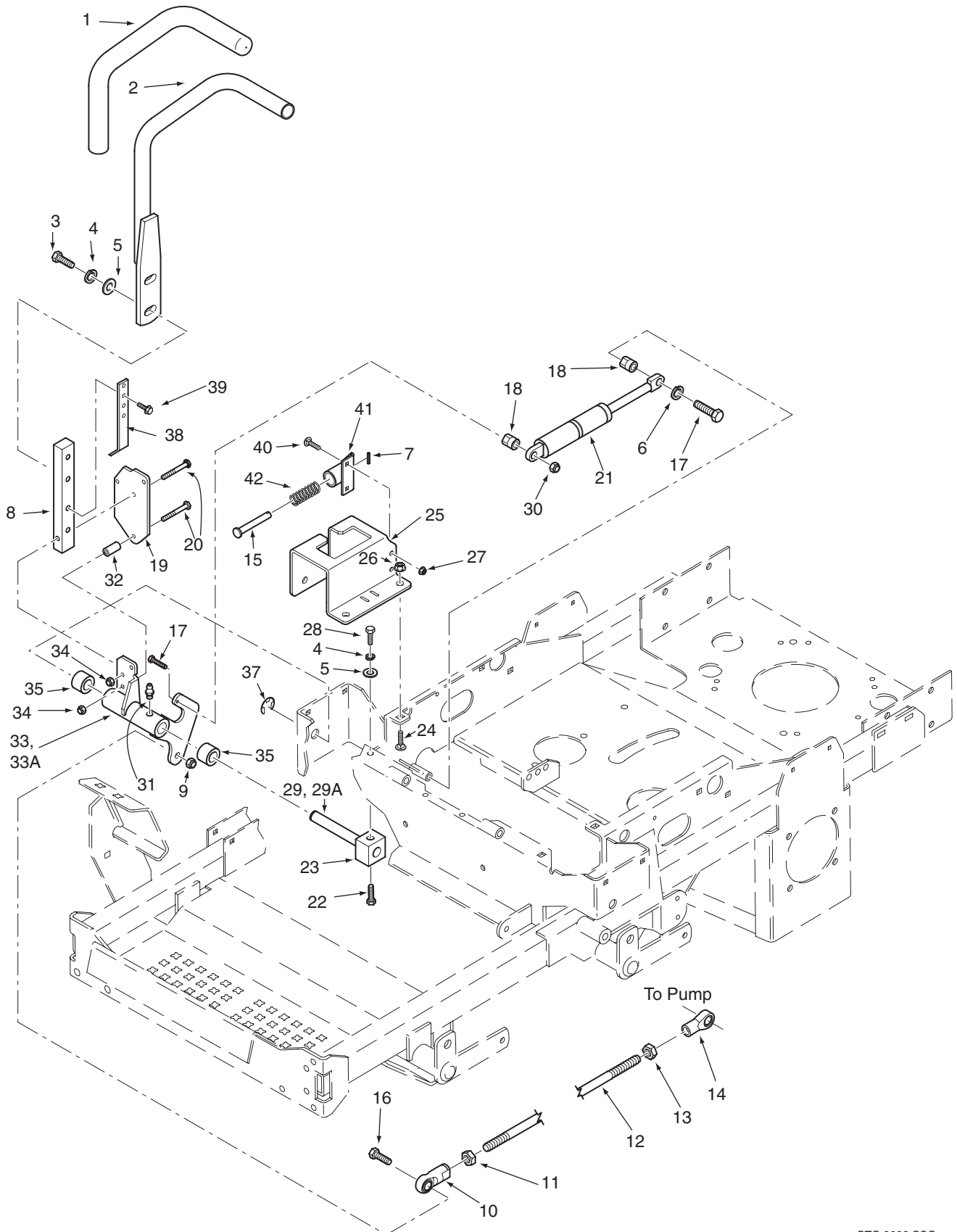

STEERING COMPONENTS

Ref. No.	Part No.	Description
1	482340	Grip, Control Lever
2	461386	Handle Bar (Includes item 1)
3	04001-32	Bolt, Hex Head 3/8-16 x 1-1/4"
4	04030-04	Lockwasher, 3/8"
5	04041-07	Flatwasher, 3/8-.391 x .938 x .105"
6	04040-15	Flatwasher, 5/16-.375 x .875 x .083"
7	04060-01	Roll Pin, Spring 5/32 x 3/4"
8	422372	Bar, Control Lever
9	04021-09	Nut, Elastic Stop 3/8-16
10	482330	Rod End, 3/8-24 RH Female
11	04020-14	Nut, 3/8-24 RH Thread
12	482623	Rod, Pump Control Linkage
13	04020-17	Nut, 3/8-24 UNF-2B LH Thread
14	482331	Rod End, 3/8-24 LH Thread
15	43477	Pin Retainer
16	04001-20	Bolt, Hex Head 3/8-16 x 1-1/2"
17	04001-12	Bolt, Hex Head 5/16-18 x 1-3/4"
18	43602	Spacer, Pump Dampener
19	423599	Plate, Control Lever
20	04001-17	Bolt, Hex Head 5/16-18 x 2"
21	484151	Gas Damper
22	04001-19	Bolt, Hex Head 3/8-16 x 1"
23	482099	Block, Clamping
24	04003-12	Bolt, Carriage, 5/16-18 x 3/4"
25	461770	Control Plate - LH (Includes Decal)
	461771	Control Plate - RH (Includes Decal)
26	04019-03	Nut, Serr., Flange, 5/16-18
27	04021-08	Nut, Elastic Stop 1/4-20
28	04001-18	Bolt, Hex Head 3/8-16 x 3/4"
29	43616	Shaft, Steering Control
30	04021-10	Nut, Elastic Stop 5/16-18
31	48114-04	Grease Fitting, 1/4-28 Self Tap
32	43559	Spacer, Control
33	49574	Control Lever Assy RH (Includes 31 & 35)
	49573	Control Lever Assy LH (Includes 31 & 35)
34	04021-10	Nut, Elastic Stop 5/16-18
35	48100-06	Bushing
36	04041-08	Flatwasher, 1-1/4 x 49/64 x 16 Ga.
37	04050-02	Retaining Ring, 3/4" Ext.
38	423057	Bracket, Switch Actuator
39	04017-16	Bolt, Hex Serr. Flange 5/16-18 x 3/4"
40	04003-02	Bolt, Carr. 1/4-20 x 3/4"
41	45918	Bracket, Control Return
42	481389	Spring
43	43477	Pin Retainer

BRAKE COMPONENTS

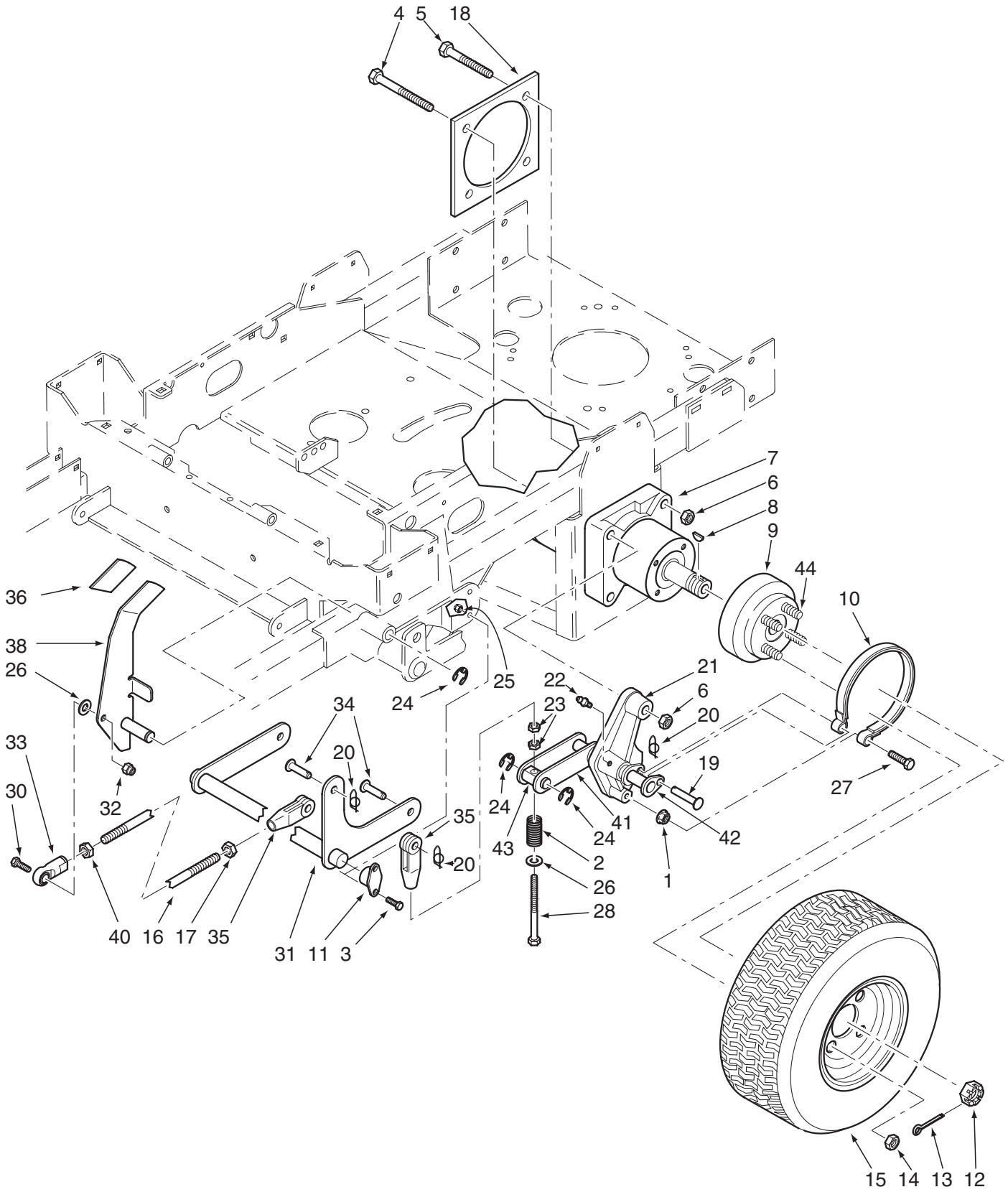

STC 2002 BSC

BRAKE COMPONENTS

Ref. No.	Part No.	Description
1	04019-06	Nut, Serr. Flange 1/2-13
2	48807	Spring
3	04001-08	Bolt, Hex Head 5/16-18 x 3/4"
4	04001-163	Bolt, Hex Head 1/2-13 x 3-3/4"
5	04001-52	Bolt, Hex Head 1/2-13 x 2-1/2"
6	04021-19	Nut, 1/2-13 Center Lock
7	482639	Wheel Motor, Parker
8	04063-25	Key, Woodruff 5/16 x 1"
9	461438	Wheel Hub Assembly
10	483644	Brake Band Assembly
11	482061	Bushing, Self Align
12	48680	Nut, Hex Castle 1.0-20 UNEF
13	04061-06	Cotter Pin, 9/64 x 1-1/2"
14	04028-02	Lug Nut, 1/2-20
15	484105	Wheel Assembly 24 x 9.5-12 (48" Cutter Deck)
	484106	Wheel Assembly 24 x 9.5-12 (52" Cutter Deck)
	481850	Wheel Assembly 24 x 12-12 (61" Cutter Deck)
	481659	Rim (48" Cutter Deck)
	482414	Rim (52" Cutter Deck)
	481851	Rim (61" Cutter Deck)
	484104	Tire 24 x 9.5-12 (48 & 52)
	481852	Tire 24 x 12-12 (61)
16	04004-46	Brake Rod Stud, 3/8-24 x 8.125"
17	04020-14	Nut, 3/8-24 UNF
18	423279	Plate Weldment, Motor Backing
19	04064-16	Clevis Pin, 3/8 x 1.93"
20	04069-01	Pin, Rue Cotter 3/8" Dia.
21	451970	Brake Linkage LH
	451971	Brake Linkage RH
22	48114-04	Grease Fitting, 1/4-28
23	04020-25	Nut, 3/8-24 UNF
24	04050-01	Retaining Ring, .625" Ext.
25	04021-10	Nut, Elastic Stop 5/16-18
26	04041-07	Flatwasher, 3/8-.391 x .938 x .105"
27	04001-187	Bolt, Hex Head 1/2-13 x 2-1/2" Grade 8
28	04001-166	Bolt, Hex Head 3/8-24 x 3-3/4"
29	04061-02	Cotter Pin, 3/32 x 3/4"
30	04001-20	Bolt, Hex Head 3/8-16 x 1-1/2"
31	451463	Brake Shaft
32	04021-09	Nut, Elastic Stop 3/8-16
33	48544	Rod End, 3/8-24 LH Thread
34	04064-02	Clevis Pin, 3/8 x 1.06"
35	48343-04	Clevis, 3/8-24
36	482102	Grip, Brake Lever
37	04019-04	Nut, Serr. Flange 3/8-16
38	461509	Brake Lever (includes item 36)
39	04001-22	Bolt, Hex Head 3/8-16 x 2-3/4"
40	04020-17	Nut, 3/8-24 UNF-2B LH Thread
41	422483	Lever, Brake
42	45974	Shaft Weldment, Pivot
43	43495	Pin, Pivot
44	04008-01	Bolt, Serr. Flange 1/2-20 x 4.563"

HYDRAULIC SYSTEM

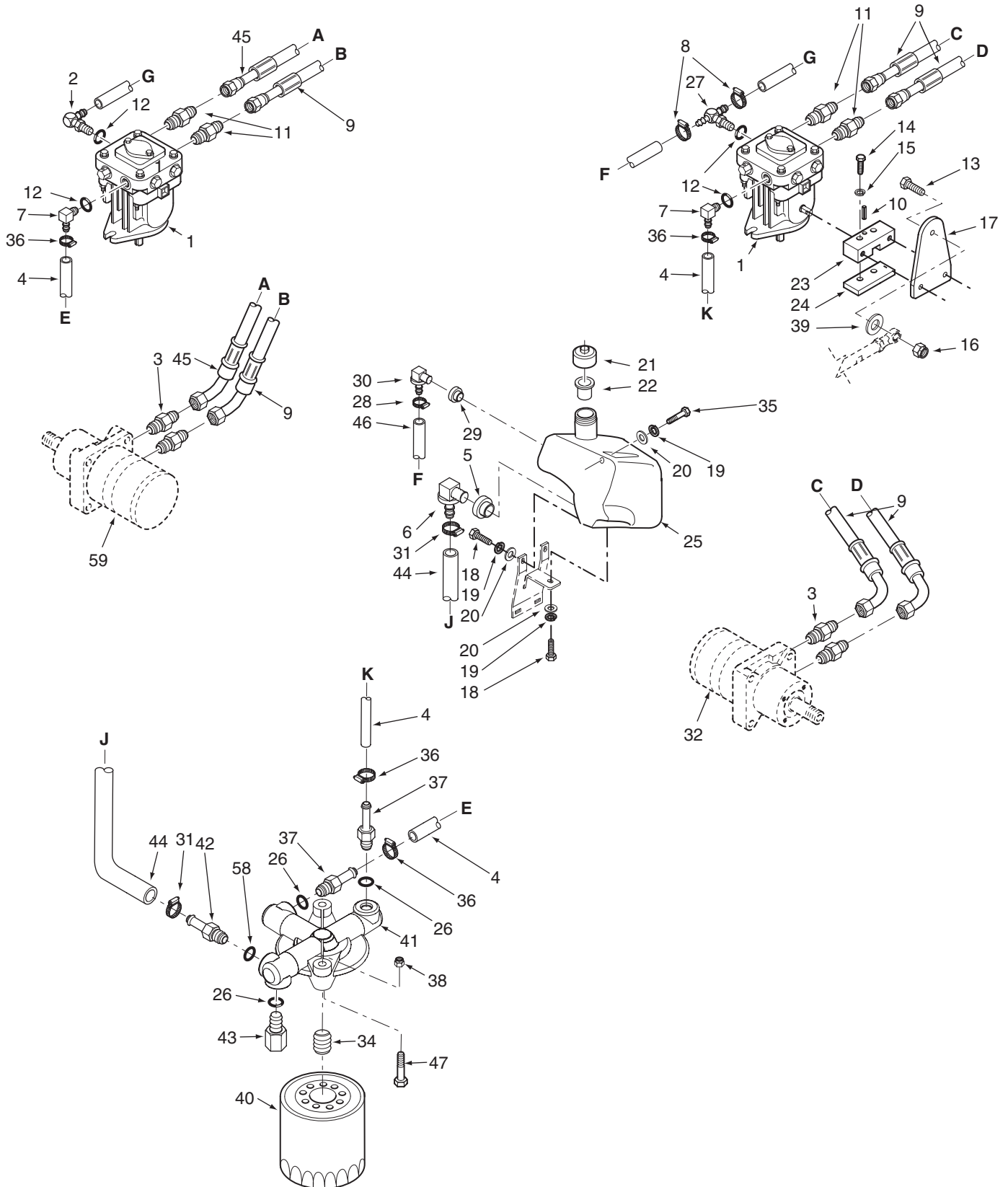

HYDRAULIC SYSTEM

Ref. No.	Part No.	Description
1	482643	Pump, BDP-10A-316 (LH)
	482644	Pump, BDP-10A-419 (RH)
2	482266-01	Elbow, 90 Degree 9/16" O-Ring x 3/8" Hose
3	48572-02	Fitting, 1/2" JIC x 5/8" O-Ring
4	48811	Hose, 3/8" Pushlock (Specify length)
5	482573	Bushing
6	482574	Fitting
7	482266-01	Elbow, 90 Degree 9/16" O-Ring x 3/8" Hose
8	48136-13	Hose Clamp, .69" Dia.
9	482548	Hose Assembly
10	04060-06	Roll Pin
11	48572-04	Fitting, 1/2" JIC x 1/2" O-Ring
12	48603-06	O-Ring
13	04001-20	Bolt, Hex Head 3/8-16 x 1-1/2"
14	04017-07	Bolt, Hex Head 1/4-20 x 1-1/4"
15	04030-02	Lockwasher
16	04021-09	Nut, Elastic Stop 3/8-16
17	422969	Control Lever
18	04001-08	Bolt, Hex Head 5/16-18 x 3/4"
19	04030-03	Lockwasher, 5/16"
20	04040-15	Flatwasher, 5/16-.375 x .875 x .083
21	481164	Cap, Hydraulic Tank
22	481507	Insert, Filler Neck
23	48829	Control Block
24	421203	Clamp Plate
25	461479	Hydraulic Tank Assembly w/Fittings
26	48603-06	O-Ring, 9/16"
27	482277	Tee Fitting, O-Ring to Barb
28	48136-13	Clamp, .69" Max. / .25" Min. Dia.
29	482571	Bushing
30	482572	Elbow, 0.38" Hose
31	48136-13	Clamp
32	482639	Wheel Motor, Parker
33	48603-02	O-Ring, 3/4"
34	482802	Nipple, Oil Filter 1.0-12 UNF-2A x 1-1/4"
35	04001-11	Bolt, Hex Head 5/16-18 x 1-1/2"

Ref. No.	Part No.	Description
36	48136-13	Clamp, .69" Max. / .25" Min. Dia.
37	482800-02	Fitting, 9/16" O-Ring x 3/8" Hose
38	04019-03	Nut, Serr. Flange 5/16-18
39	04041-07	Flatwasher, 3/8-.391 x .938 x .105"
40	48462-01	Oil Filter
41	482798	Filter Head Assembly
42	482800-01	Fitting, 3/4" O-Ring x 3/8" Hose
43	48604-03	Plug, 9/16-18 O-Ring
44	482557	Hose, Filter Inlet
45	482605	Hose Assembly
46	48811	Hose, 3/8" Pushlock 15" Long
47	04001-17	Bolt, Hex Head 5/16-18 x 2"

** Available through the individual engine manufacturer.

STC FUEL SYSTEM - EPA PHASE 2 (models produced prior to 1/1/2011)

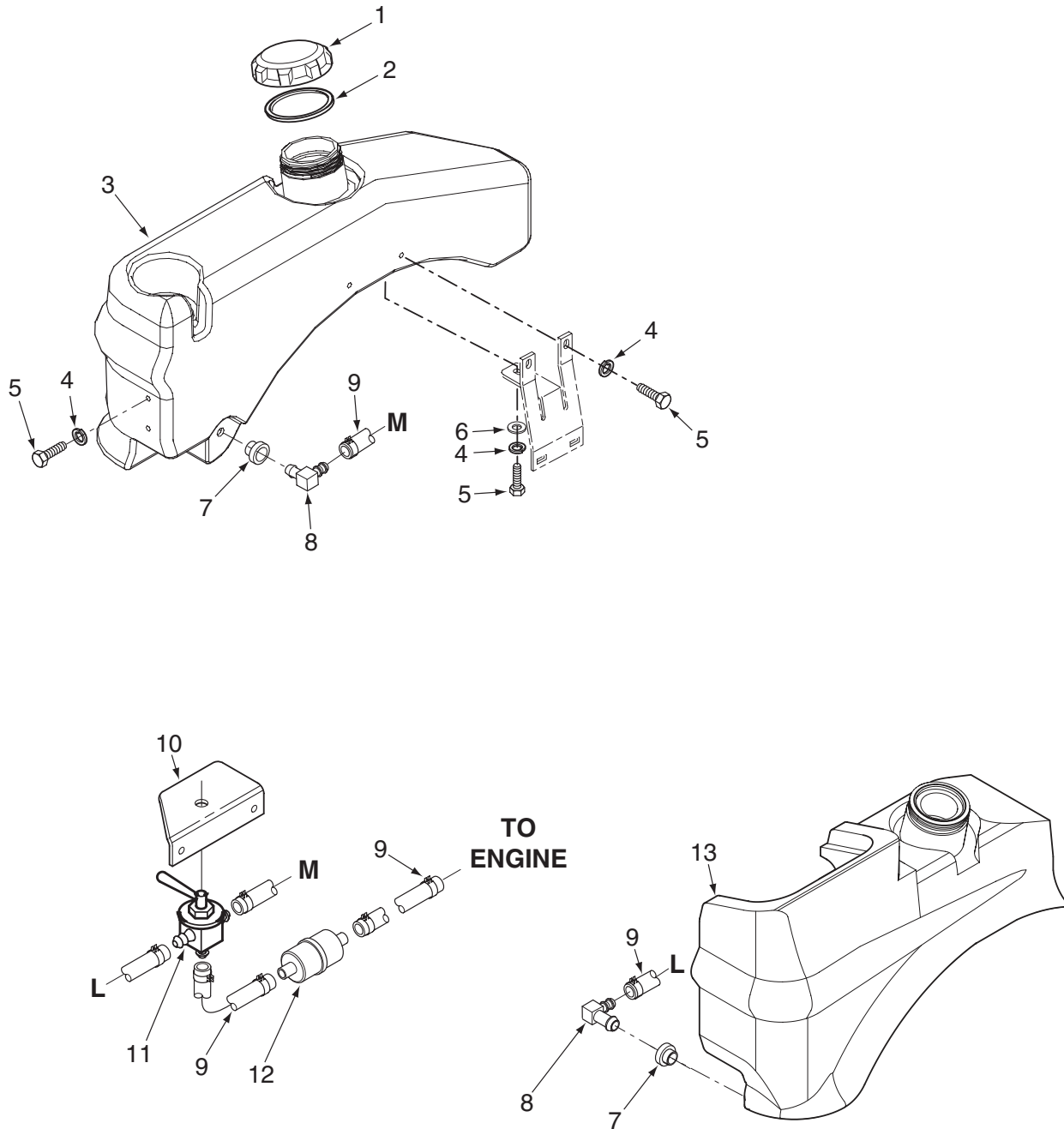

STC 2011 FS EPA PHASE 2

**STC FUEL SYSTEM - EPA PHASE 2
(models produced prior to 1/1/2011)**

Ref. No.	Part No.	Description
1	483792	Fuel Cap
2	482774	Gasket, Fuel Cap
3	462163	Fuel Tank RH (incl. #7 & #8)
4	04030-03	Lockwasher, 5/16" Spring
5	04001-08	Bolt, Hex Head 5/16-18 x 3/4"
6	04040-15	Flatwasher, 5/16-.375 x .875 x .083
7	482571	Tank Bushing
8	483748	Fitting, 90 Degree
9	483617	Fuel Hose, 1/4" I.D. Non-Perm (order by inch)
10	423912	Bracket, Fuel Valve
11	482212	Fuel Shutoff Valve
12	*	Fuel Filter
13	462162	Fuel Tank LH (incl. #7 & #8)

* = Available through engine manufacturer only.

STC FUEL SYSTEM - EPA PHASE 3 (models produced after 1/1/2011)

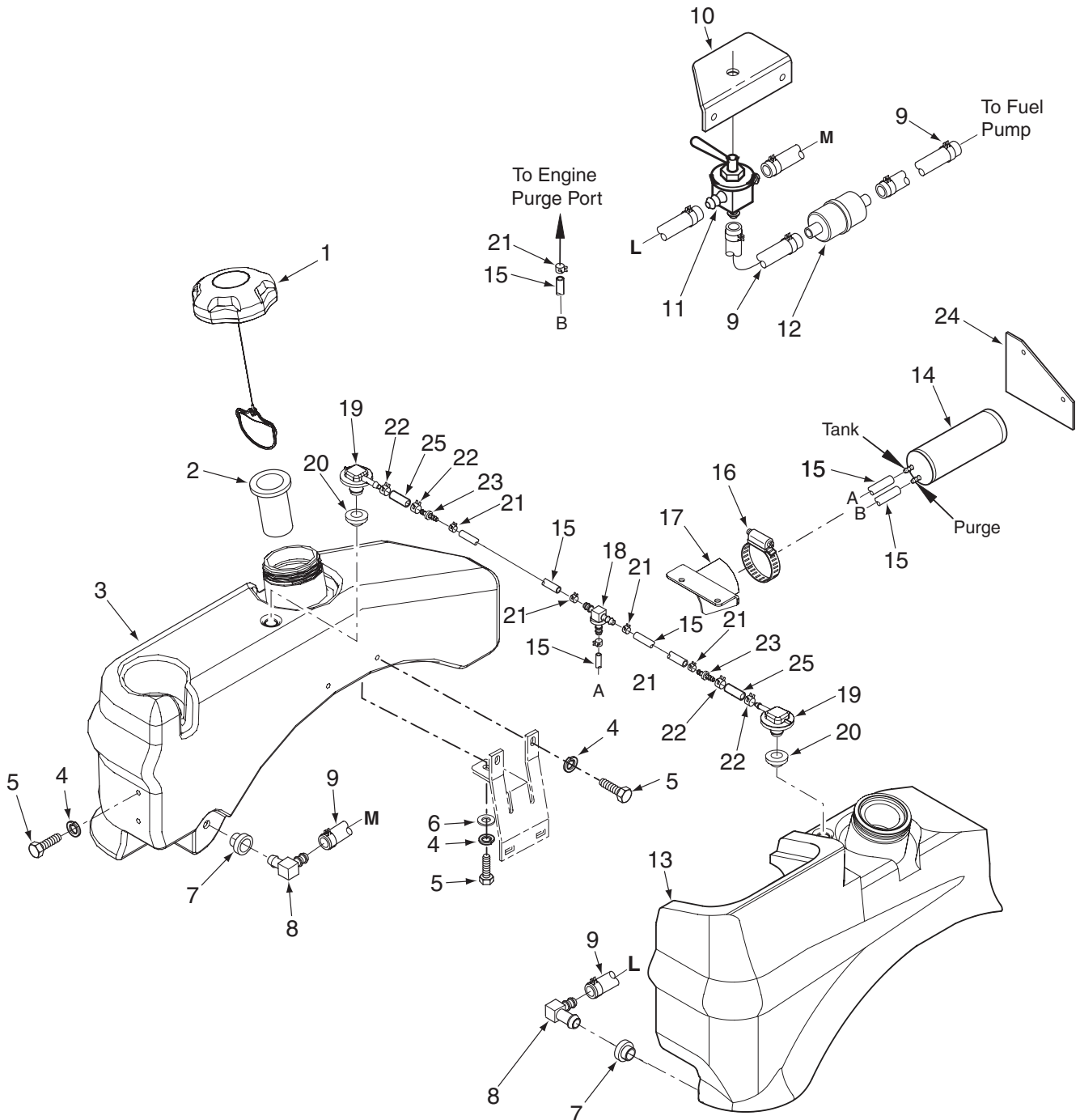

**STC FUEL SYSTEM - EPA PHASE 3
(models produced after 1/1/2011)**

Ref. No.	Part No.	Description
1	484286	Fuel Cap w/ Tethered
2	484279-01	Tube, Fuel Tank Insert
3	462296	Fuel Tank RH (incl. #7 & #8)
4	04030-03	Lockwasher, 5/16" Spring
5	04001-08	Bolt, Hex Head 5/16-18 x 3/4"
6	04040-15	Flatwasher, 5/16-.375 x .875 x .083
7	482571	Tank Bushing
8	483748	Fitting, 90 Degree
9	483617	Fuel Hose, 1/4" I.D. Non-Perm (order by inch)
10	423912	Bracket, Fuel Valve
11	482212	Fuel Shutoff Valve
12	*	Fuel Filter
13	462295	Fuel Tank LH (incl. #7 & #8)
14	484342	Carbon Canister
15	484347	Hose, 3/16" (order by inch)
16	48136-17	Clamp
17	452176	Bracket, Canister Mounting
18	48935-02	T - Fitting, Fuel Vent
19	484284	Valve, Rollover
20	484285	Grommet, Viton
21	48059-05	Clamp, Vapor Recovery Hose 3/16"
22	48059-02	Clamp, Fuel Hose
23	484343-01	Mender, 1/4 x 3/16 w/.02 Hole
24	425559	Heatshield
25	484347	Hose, 1/4" Vapor Recovery (order by inch)

* = Available through engine manufacturer only.

**STC FUEL SYSTEM - C.A.R.B. TIER 3
(LE models only - Produced after 1/1/2010)**

Ref. No.	Part No.	Description
1	484297	Fuel Cap w/ Tethered (C.A.R.B.)
2	484279-01	Tube, Fuel Tank Insert
3	462296	Fuel Tank RH (incl. #7 & #8)
4	04030-03	Lockwasher, 5/16" Spring
5	04001-08	Bolt, Hex Head 5/16-18 x 3/4"
6	04040-15	Flatwasher, 5/16-.375 x .875 x .083
7	482571	Tank Bushing
8	483748	Fitting, 90 Degree
9	483617	Fuel Hose, 1/4" I.D. Non-Perm (order by inch)
10	423912	Bracket, Fuel Valve
11	482212	Fuel Shutoff Valve
12	*	Fuel Filter
13	462295	Fuel Tank LH (incl. #7 & #8)
14	484342	Carbon Canister
15	484347	Hose, 3/16" (order by inch)
16	48136-17	Clamp
17	452176	Bracket, Canister Mounting
18	48935-02	T - Fitting, Fuel Vent
19	484284	Valve, Rollover
20	484285	Grommet, Viton
21	48059-05	Clamp, Vapor Recovery Hose 3/16"
22	48059-02	Clamp, Fuel Hose
23	484343-01	Mender, 1/4 x 3/16 w/.02 Hole
24	425559	Heatshield
25	484347	Hose, 1/4" Vapor Recovery (order by inch)

* = Available through engine manufacturer only.

ELECTRICAL SYSTEM

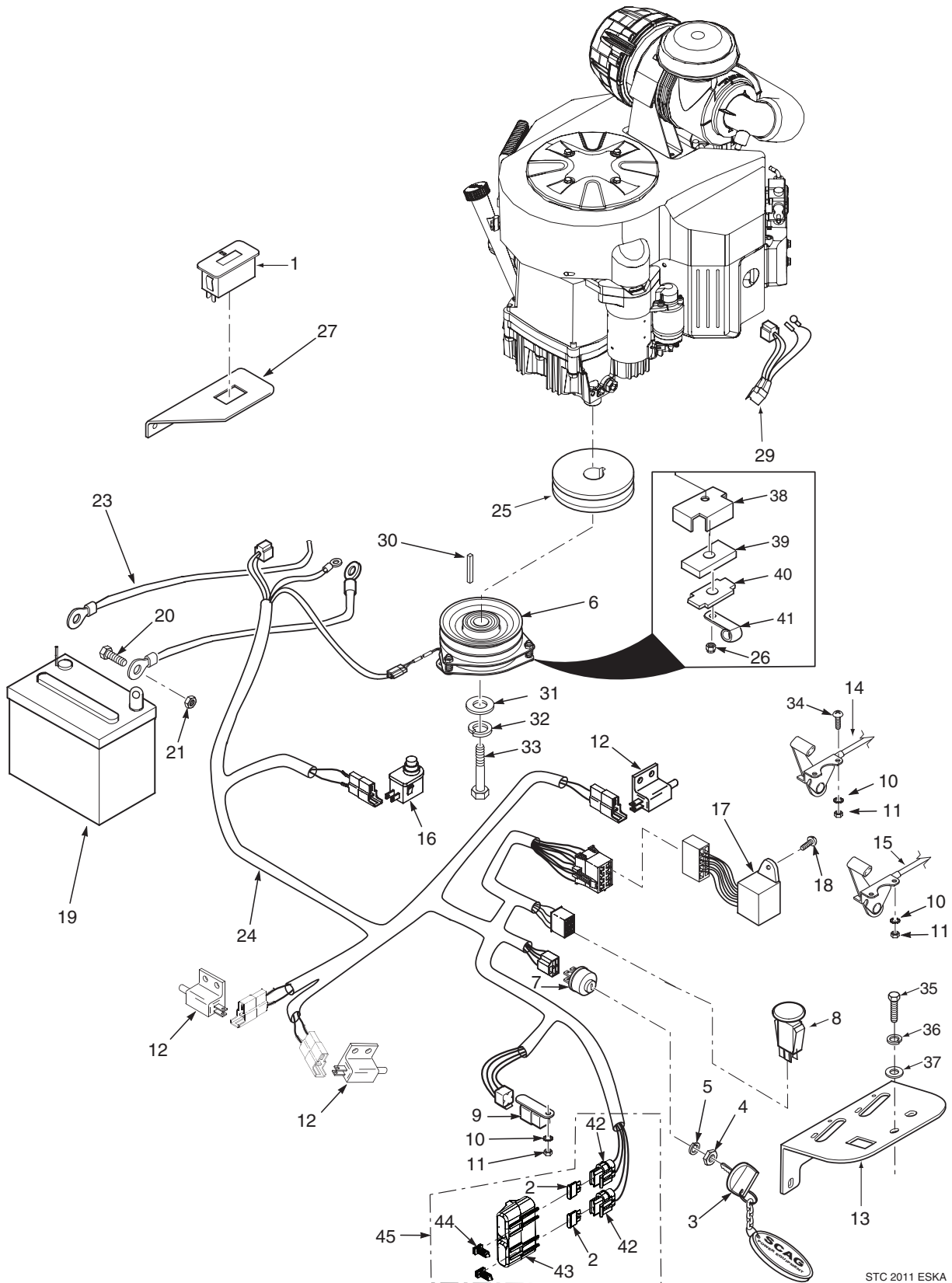

STC 2011 ESKA

ELECTRICAL SYSTEM

Ref. No.	Part No.	Description
1	483537	Hourmeter
2	48298	Fuse, 20 amp
3	483366	Key, Ignition
	462069	Key Assembly w/Fob
4	48017-04	Nut, Hex 5/8-32
5	48017-03	Lockwasher, 5/8" Internal
6	461660	Electric PTO Clutch GT3.5
7	48798	Switch, Ignition
8	483957	Switch, PTO
9	483013	Relay
10	04031-01	Lockwasher, #10 External Tooth
11	04020-01	Nut, Hex #10-32
12	481637	Switch, N/O
13	461768	Panel, Instrument
14	482032	Choke & Throttle Control - Kawasaki (Qty 2)
	481544	Choke Control - Kohler (Qty 1)
15	482032	Throttle Control - Kohler (Qty 1)
16	481638	Switch, Seat
17	483599	Module, Interlock
18	04010-01	Screw, #10-32 x .5" Phillips Head
19	483665	Battery, 350CCA (Not Available Through Scag)
20	04001-44	Bolt, Hex Head 1/4-20 x .5"
21	04020-02	Nut, Hex 1/4-20
22	48029-15	Cable, Battery Black (negative)
23	48029-12	Cable, Battery Red (positive)
24	483618	Wiring Harness, Main (Briggs & Stratton, Kohler)
	484178	Wire Harness, Main (Kawasaki)
25	483081	Pulley, 5.45 OD x 1.125" Bore
26	04021-10	Nut, Elastic Stop 5/16-18 Key
27	424112	Mounting Bracket, Hour Meter
28	04010-11	Screw, #10-32 x 1.5" Phillips Head
29	482836	Adapter, Wiring Harness (Briggs & Stratton only)
	484179	Adapter, Wiring Harness (Kawasaki FX only)
	484299	Adapter, Wiring Harness (Kawasaki FS only)
	484078	Adapter, Wiring Harness (Kohler only)
30	04063-23	Key, 1/4 x 1/4 x 3-1/4"
31	04041-28	Flatwasher, 7/16-.469 x 1-3/4" x 1/4"
32	04030-05	Lockwasher, 7/16"
33	04001-101	Bolt, Hex Head 7/16-20 x 2-1/2" UNF
34	04010-12	Screw, #10-32 x 3/4"
35	04001-08	Bolt, Hex Head 5/16-18 x 3/4"
36	04030-03	Lockwasher, 5/16"
37	04040-15	Flatwasher, 5/16-.375 x .875 x .083
38	423909	Backing Plate
39	481716	Rubber Pad, Clutch Stop
40	422534	Plate, Backing
41	48030-09	Clamp
42	483629	Fuse Holder
43	483571	Cover, Sealed Double

BDP-10A HYDRAULIC PUMP ASSEMBLY

Ref. No.	Part No.	Description
1	HG 70516	Housing Kit
2	HG 70573	End Cap Kit
3	HG 50641	Straight Headless Pin
4	HG 50969	Hex Flange Bolt, M8-1.25 x 60mm
5	HG 51232	Housing O-Ring
6	HG 2513027	Charge Pump Kit
7	HG 50273	Gerotor Assembly
8	HG 9004101-1340	O-Ring
9	HG 50095	Socket Head Screw, M6 x 1.0-20mm
10	HG 2513030	Bypass Valve Kit
11	HG 70521	Pumpshaft Kit
12	HG 50315	Ball Bearing, 17 x 40 x 12mm
13	HG 51161	Lip Seal
14	HG 50329	Retaining Ring
15	HG 50951	Spacer
16	HG 70331	Cylinder Block Kit
17	HG 2003014	Block Spring
18	HG 2003017	Block Thrust Washer
19	HG 51444	Valve Plate
20	HG 2003087	Swash Plate
21	HG 50551	Ball Thrust Bearing
22	HG 2003005	Trunnion Arm
23	HG 2000015	Slot Guide
24	HG 2510062	Check Valve Kit (.024" Orifice) port "A" on Left Hand Pump, port "B" on Right Hand Pump
25	HG 70403	Charge Relief Kit
26	HG 2513043	Trunnion Seal with Retainer
27	HG 9005110-4400	Straight Thread Plug
28	HG 50408	Straight Headless Pin
29	HG 70525	Overhaul Seal Kit
30	HG 70743	System Check Relief Kit, port "B" on Left Hand Pump, port "A" on Right Hand Pump

REPLACEMENT DECALS AND INFORMATION PLATES

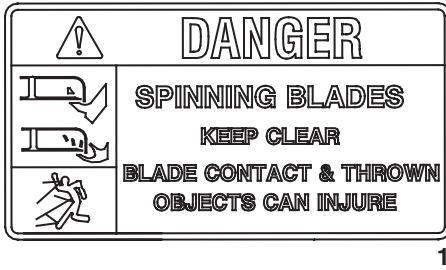

1

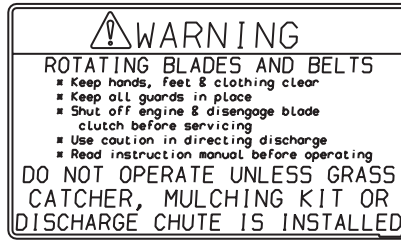

2



8

48404

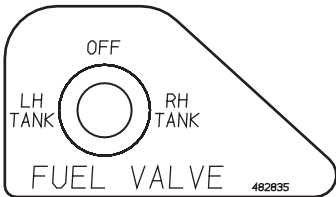

11

482835

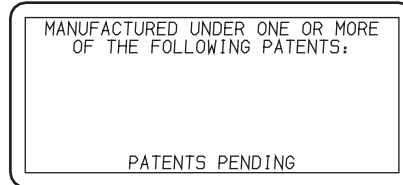

5



13

483838



6

482100



7

481971

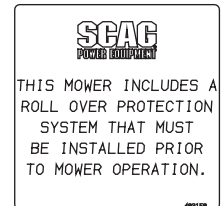

4

481158



9

483402

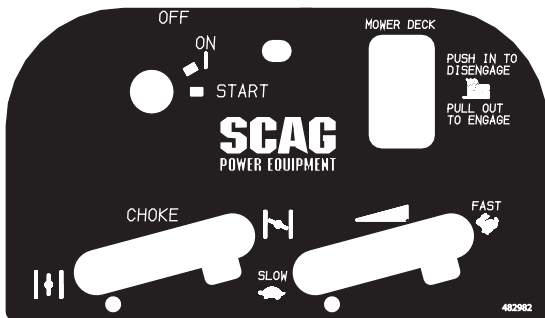

10

482982

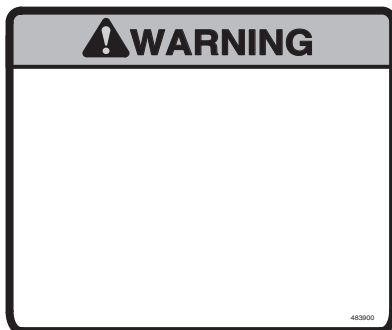

19

483900



12

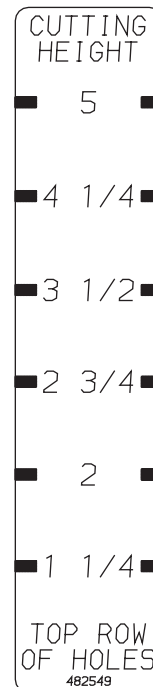

18

REPLACEMENT DECALS AND INFORMATION PLATES

Ref. No.	Part No.	Description
1	483407	Decal, Danger-Spinning Blades
2	483406	Decal, Warning-Rotating Blades
3	483199	Decal, 48V
	483200	Decal, 52V
	483201	Decal, 61V
4	483158	Decal, ROPS
5	483044	Decal, Patents
6	482100	Decal, Traction Control
7	481971	Decal, Heavy Duty Commercial
8	48404	Decal, Metalcraft - Made in USA
9	483402	Decal, Belt Cover
10	482982	Decal, Instrument Panel
11	482835	Decal, Fuel Valve Position
12	482566	Decal, Cutting Height Bottom Row of Holes
13	483838	Decal, Tiger Cat
14	482709	Decal, Seat Support
15	483839	Decal, Rear Bumper
16	482166	Decal, Front Footplate
17	483405	Decal, Discharge Chute
18	482549	Decal, Cutting Height Top Row of Holes
19	483900	Decal, Warning Spark Arrestor (California only)
**	461983	Spanish Decal Kit, STC / STWC (not shown)
**	01411	DVD Video, Tips for Safe Operation of Your Scag Zero-Turn Mower

IMPORTANT ADJUSTMENT PROCEDURES
READ OPERATOR'S MANUAL FOR MORE DETAILS
 Check tire pressure - (Drive tires-12 psi)
 - (Caster tires-25 psi)

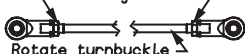
NEUTRAL ADJUSTMENT
 Loosen jam nuts

 Rotate turnbuckle

With an operator in the seat, engine running, control lever in neutral and the parking brake disengaged - adjust control linkage. Loosen jam nuts. If wheel rotates forward, adjust turnbuckle CW. If wheel rotates rearward, adjust turnbuckle CCH. Adjust until drive wheel stops turning. Tighten jam nuts. Repeat procedure until proper Neutral Adjustment is obtained.

TRACKING ADJUSTMENT
 If the machine pulls to the right, adjust LH control linkage CW to slow left wheel. If the machine pulls to the left adjust RH control linkage CW to slow right wheel. Readjust neutral if necessary.

FREE WHEEL OPERATION
 To move machine without running the engine, rotate both dump valves located at the LH side of the pumps CCH 1/2 turn to "freewheel" positions. Return dump valves to original position to operate the mower. Tighten to 7-10 ft.-lbs.

HYDRAULIC FLUID LEVEL
 Check hydraulic fluid level while fluid is cool. Fluid level should be 3" below top of filler neck. Fill with SAE 20W50 motor oil only.

IMPORTANT
 Do not overfill. Room for hot fluid expansion must be allowed or resulting expansion may cause leaks in the system.

482709

14



15



3



16



17

ELECTRICAL SCHEMATIC - BRIGGS & STRATTON / KOHLER

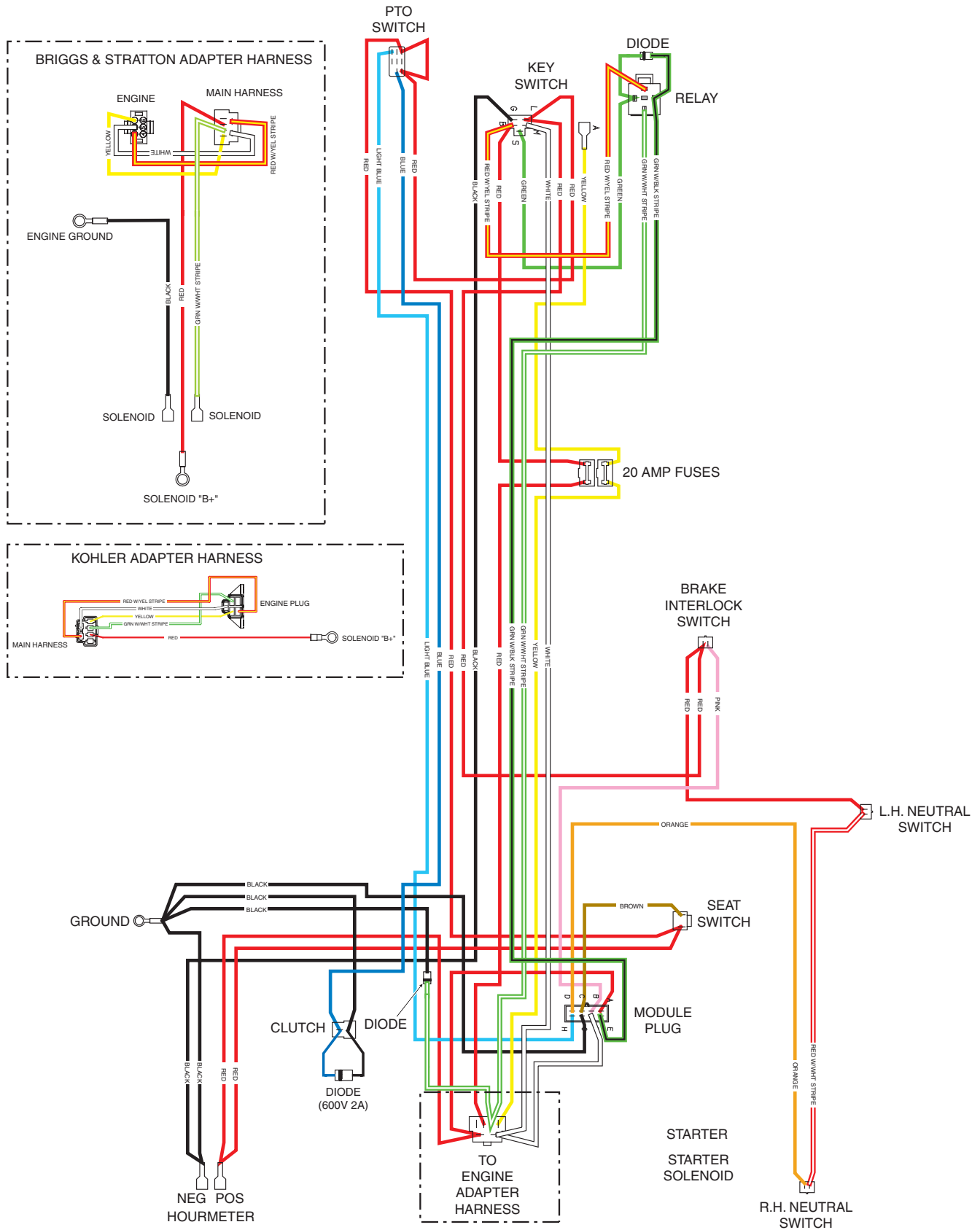

ELECTRICAL SCHEMATIC - KAWASAKI

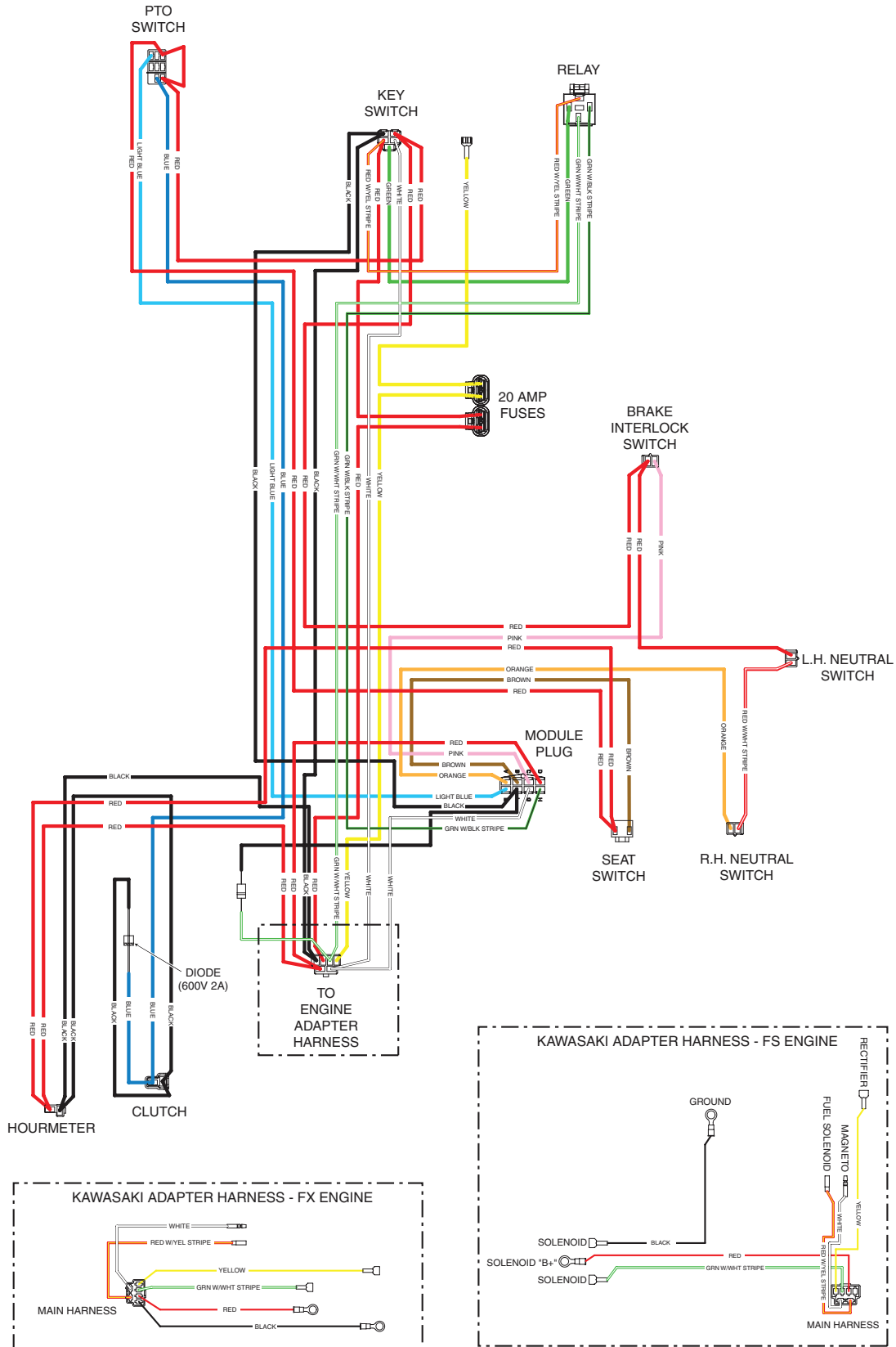

2011 STC FX & FS Electrical Schematic

LIMITED WARRANTY - COMMERCIAL EQUIPMENT

Any part of the Scag commercial mower manufactured by Scag Power Equipment and found, in the reasonable judgment of Scag, to be defective in materials or workmanship, will be repaired or replaced by an Authorized Scag Service Dealer without charge for parts and labor during the periods specified below. This warranty is limited to the original purchaser provided the product was purchased from an Authorized Scag Power Equipment Dealer and is not transferable. Proof of purchase will be required by the dealer to substantiate any warranty claims. All warranty work must be performed by an Authorized Scag Service Dealer.

This warranty is limited to the following specified periods from the date of the original retail purchase for defects in materials or workmanship:

- Wear items including drive belts, blades, hydraulic hoses and tires are warranted for ninety (90) days.
- Batteries are covered for ninety (90) days.
- Frame and structural components including oil reservoir and oil coolers are warranted for two (2) years (parts and labor) for commercial use or three (3) years / 500 hours (whichever comes first) (parts and labor) for non-commercial use.
- Cutter decks are warranted against cracking for a period of three (3) years. (parts and labor 1st and 2nd year; parts only 3rd year.) The repair or replacement of the cutter deck will be at the option of Scag Power Equipment. We reserve the right to request components for evaluation. This warranty does not cover any mower that has been subject to misuse, neglect, negligence, or accident, or that has been operated in any way contrary to the operating instructions as specified in the Operator's Manual.
- Engines and electric starters are covered by the engine manufacturer's warranty period.
- Major drive system components are warranted for two (2) years (parts and labor) for commercial use or three (3) year / 500 hour (whichever comes first) (parts and labor) for non-commercial use by Scag Power Equipment. (commercial and non-commercial warranty excludes fittings, hoses, drive belts). The repair or replacement of the hydraulic pump or hydraulic motor will be at the option of Scag Power Equipment. This warranty does not cover any mower that has been subject to misuse, neglect, negligence, or accident, or that has been operated in any way contrary to the operating instructions as specified in the Operator's Manual.
- Electric clutches have a Limited Warranty for two (2) years (parts and labor) for commercial use or three (3) year / 500 hours (whichever comes first) (parts and labor) for non-commercial use.
- Spindle assemblies have a Limited Warranty for three years (parts and labor 1st year and 2nd; parts only 3rd year).
- Any Scag product used for rental purposes is covered by a 90 day warranty.

The Scag mower, including any defective part must be returned to an Authorized Scag Service Dealer within the warranty period. The expense of delivering the mower to the dealer for warranty work and the expense of returning it to the owner after repair will be paid for by the owner. Scag's responsibility is limited to making the required repairs and no claim of breach of warranty shall be cause for cancellation or rescission of the contract of sale of any Scag mower. "Non-Commercial" use is defined as a single property owner, where the single property is the residence of the owner of the mower. If the mower is cutting more than the owners single property, it is deemed commercial use and the "non-commercial" warranty does not apply. Scag Power Equipment reserves the right to deny and / or void the non-commercial warranty if it believes it to be in commercial use.

This warranty does not cover any mower that has been subject to misuse, neglect, negligence, or accident, or that has been operated in any way contrary to the operating instructions as specified in the Operator's Manual. The warranty does not apply to any damage to the mower that is the result of improper maintenance, or to any mower or parts that have not been assembled or installed as specified in the Operator's Manual and Assembly Manual. The warranty does not cover any mower that has been altered or modified, changing performance or durability. In addition, the warranty does not extend to repairs made necessary by normal wear, or by the use of parts or accessories which, in the reasonable judgment of Scag, are either incompatible with the Scag mower or adversely affect its operation, performance or durability.

Scag Power Equipment reserves the right to change or improve the design of any mower without assuming any obligation to modify any mower previously manufactured. All other implied warranties are limited in duration to the two (2) year for commercial use, three (3) years / 500 hour for non-commercial use or ninety (90) days for mowers used for rental purpose. Accordingly, any such implied warranties including merchantability, fitness for a particular purpose, or otherwise, are disclaimed in their entirety after the expiration of the appropriate two year or ninety day warranty period. Scag's obligation under this warranty is strictly and exclusively limited to the repair or replacement of defective parts and Scag does not assume or authorize anyone to assume for them any other obligation. Some states do not allow limitations on how long an implied warranty lasts, so the above limitation may not apply to you.

Scag assumes no responsibility for incidental, consequential or other damages including, but not limited to, expense for gasoline, expense of delivering the mower to an Authorized Scag Service Dealer and expense of returning it to the owner, mechanic's travel time, telephone or telegram charges, rental of a like product during the time warranty repairs are being performed, travel, loss or damage to personal property, loss of revenue, loss of use of the mower, loss of time or inconvenience. Some states do not allow the exclusion or limitation of incidental or consequential damages, so the above limitation or exclusion may not apply to you. This warranty gives you specific legal rights, and you may also have other rights which vary from state to state.

